

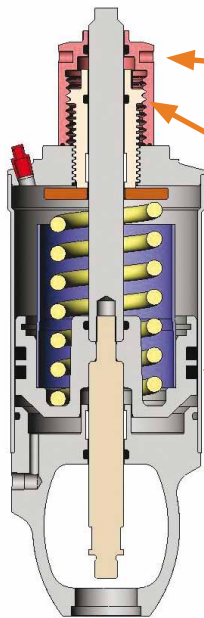

# Over-Pressure Single Seat Valves

## Pump Over-Pressure Protection

Fit your pump with an external over-pressure relief valve. If pump discharge pressure exceeds the set cracking-pressure, the valve will open to a relief path. The Adjustable-Spring actuator lets you set the desired relief cracking pressure right at the valve by simply turning the adjustment screw (see below). Three diameters are available: 4", 5" and 6" for both air-to-raise (AR) on 1.5" – 4" W61 valves, and air-to-lower (AL) on 2"-4" W63 valves. TFP Seats are required for strength and durability. For clean-in-place applications (CIP), a piston in the actuator allows opening of the valve without having to over pressure it. After relieving or CIP is complete, the valve reseats in place.

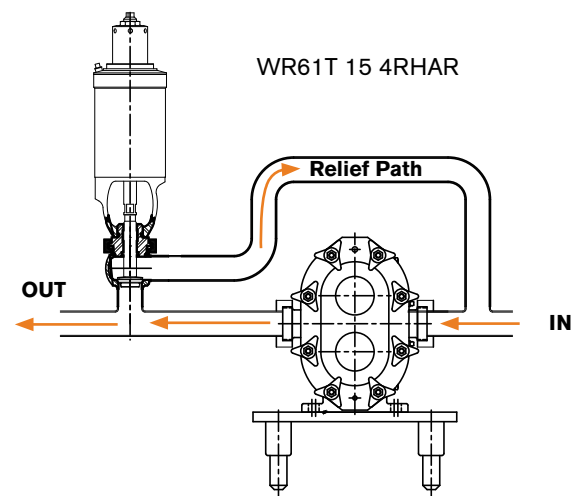

- **Exterior Adjustment** with sealed cap to safeguard threaded area. No exposed threads!

- **Positive-Stop** prevents overloading of spring and engages with the sealed cap to lock in the setting.

Cracking pressure adjustment range from zero (fully unloaded) to maximum published holding pressure of standard, heavy-spring actuators.

- **Piston** for full opening/ by-pass

Heavy-duty construction with (3) bearing locations and sealed, welded construction.

Pump Over-Pressure valves are designated as WR60 and WR80 Series Valves.

NOTE: Not an ASME rated device or SRV. Not suitable for tanks or other pressure-vessels.

# Over-Pressure Protection on a Positive-Displacement Pump using the Adjustable-Spring Actuator

## Capacity Example:

- Model 30 Universal PD
- 1.5" Ports, 25 gpm
- Cracking Pressure: 100 psi
- Air-to-Raise Configuration

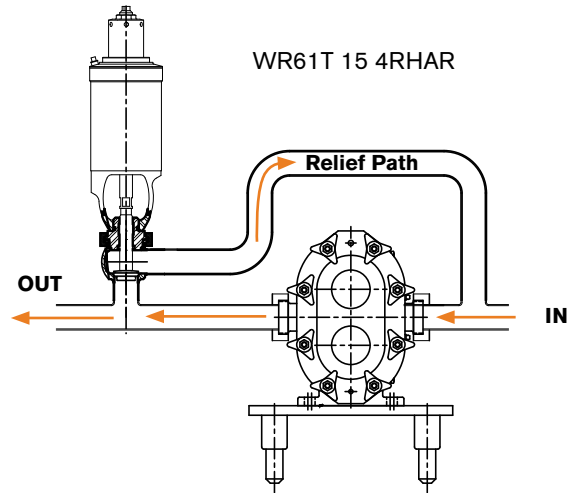

Use the W61 Holding Pressure Charts in the Operation and Maintenance manual or datasheet DS-1201 to select a maximum holding pressure higher than the desired cracking pressure for a given plug size. Use the heavy-duty actuator listings ie 4HAR. WR61 holding pressures also listed on page 6.

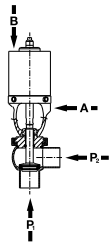

## W61 AR/HAR (air-to-raise) - Standard Stroke

	ACTUATOR SIZE (IN)	VALVE SIZE - INCHES (MM) - PRESSURE IN PSI*					
		1" (25)	1.5" (38)	2" (51)	2.5" (64)	3" (76)	4" (102)
Bottom Port (P <sub>1</sub> ), Actuator spring holds closed against:	4AR	160	125	70	45	31	18
	4HAR	213	177	99	64	44	25
	5AR	251	220	124	79	55	31
	5HAR <sup>1</sup>	---	378	212	136	94	54
	6AR	347	317	178	114	79	45
	6HAR <sup>1</sup>	---	---	338	216	150	87

### Select:

4HAR, maximum holding pressure of 177 psi.

The **4RHAR** Adjustable-Spring actuator will also hold to 177 psi max when fully loaded.

Designate the W61 as a **WR61**.

## Selection: WR61T 1.5" 4RHAR

### Set Pressure

Use tables in the Operation and Maintenance manual to estimate the number of turns off the maximum to achieve the desired relief cracking pressure.

177 psi – 100 psi **desired** cracking point = 77 psi

1.5" Plug, 4RHAR, **24 psi per turn** reduction from maximum

Turn adjustment screw 100% down (fully loaded to maximum), then back off 77/24 or approximately **3.2 turns** to achieve 100 psi cracking pressure.

Refer to page. 5, Pressure Rise Charts for performance under flow.

### Air-To-Raise Spring-Adjustable Actuator Spring Setting Pressure change per turn of adjusting screw

PLUG SIZE	ACTUATOR		
	4RHAR	5RHAR	6RHAR
1.5	24	40	82
2.0	13	23	46
2.5	9	15	29
3.0	6	10	20
4.0	3	6	12

Screw may be different due to spring variations.

# Over-Pressure Protection on a Positive-Displacement Pump using the Adjustable-Spring Actuator

For Free-draining, minimal dead-leg relief piping, use the WR63 valve, CD body and an Air-to-Lower, adjustable-spring actuator.

If pump discharge pressure exceeds the set cracking-pressure, the valve will open and relieve the over-pressure to pump suction.

## Selection: WR63CD Reverse-Acting

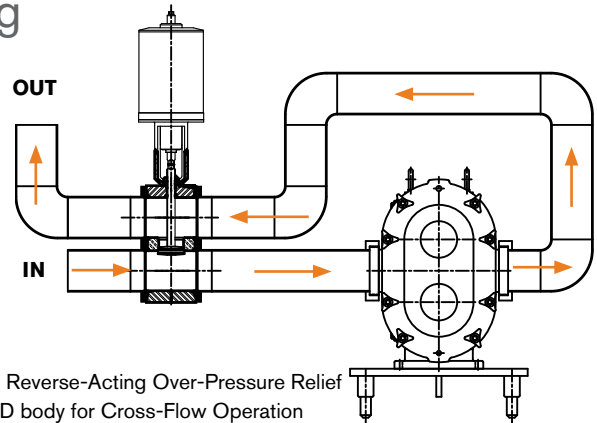

WR63 Reverse-Acting Over-Pressure Relief with CD body for Cross-Flow Operation

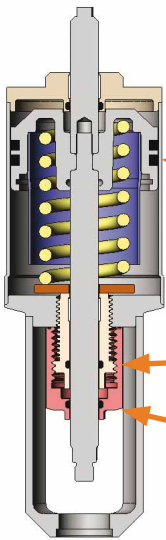

Cracking pressure adjustment range from zero (fully unloaded) to maximum published hold pressure of standard, heavy-spring actuators.

- **Piston** for full opening/by-pass

Heavy-Duty construction with (3) bearing locations and sealed, welded construction.

- **Positive-Stop** prevents overloading of spring and engages with the sealed cap to lock in the setting.

- **Exterior Adjustment** with sealed cap to safeguard threaded area.

Air-to-Lower

## Selection: WR61C Air-To-Raise Adjustable-Spring Actuator

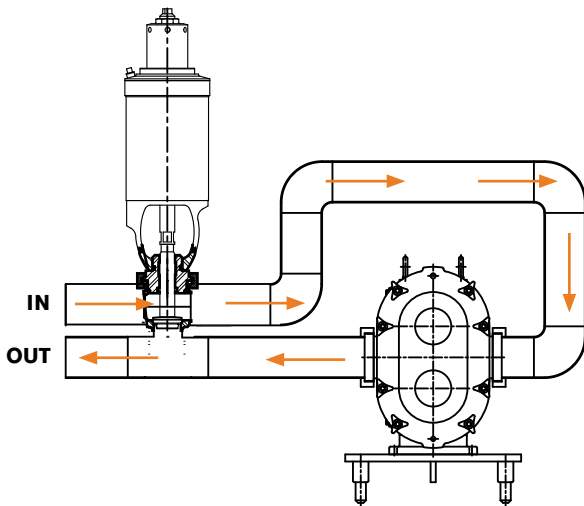

Air-to-Raise (WR61), Cross-Flow Body configurations also available for minimal dead-leg relief lines.

Use the C, CM or CPS body with a close-coupled tee as a cost effective solution.

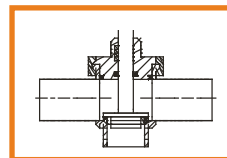

CM

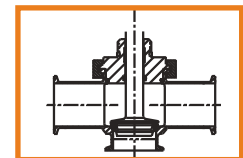

CPS

# Over-Pressure Protection using a Reduced-Seat Valve and the Adjustable-Spring Actuator

## Reduced-Seat Valve Bodies

### Capacity Example:

- Model 220 Universal PD
- 4" Ports, 115 gpm
- Cracking Point: 170 psi
- Cross-flow, minimal dead-leg
- Air-to-lower (AL) configuration

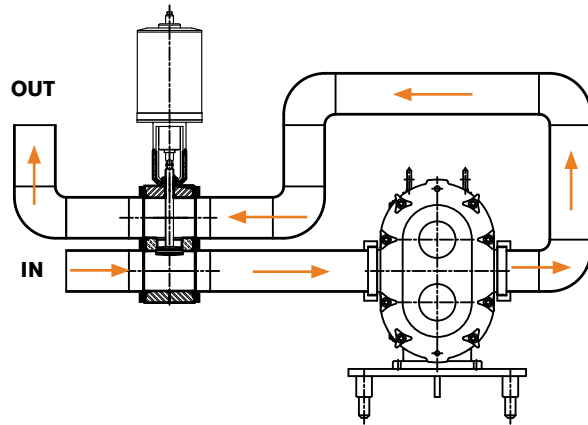

Use the W63 Holding Pressure Charts in the Operation and Maintenance manual or datasheet DS-1201 to select a maximum holding pressure higher than the desired cracking pressure for a given plug size. Use the heavy-duty actuator listings ie 4HAR. WR63 holding pressures also listed on page 6.

## WR63 AL/AHL (Air-to-Lower) - Standard Stroke

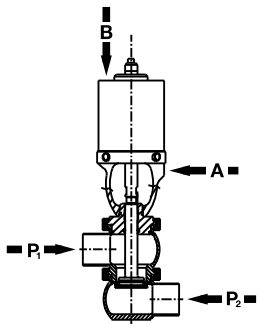

	ACTUATOR SIZE (IN)	VALVE SIZE - INCHES (MM) - PRESSURE IN PSI*					
		1" (25)	1.5" (38)	2" (51)	2.5" (64)	3" (76)	4" (102)
Port (P <sub>1</sub> ), Actuator spring holds closed against:	4AL	231	164	81	49	33	17
	4HAL <sup>1</sup>	301	233	114	69	46	24
	5AL	349	290	142	86	58	31
	5HAL <sup>1</sup>	---	497	244	147	99	52
	6AL	442	385	189	114	77	41
	6HAL <sup>1</sup>	---	---	323	195	131	68

A cracking pressure of 170 psi is achievable - with a 2.5" plug

**Selection:**  
6HAL provides 68 psi max. holding pressure on a 4" plug- not enough to achieve desired cracking pressure of 170 psi for the chosen line size.

## Reduced-Seat Selection:

### WR63CD 40/25 with the 6RHAL actuator

While the port connections and body remain 4.0", the valve plug is 2.5". So, the maximum holding pressure of the 2.5" plug can be used = 195 psi.

For Reduced-Seat valves, pressure drop, pressure rise and reseating pressure must be estimated using the 2.5" valve plug size. Refer to Pressure Rise Charts, page. 5.

When the desired cracking pressure exceeds the maximum holding pressure of the actuator- for the chosen valve size:

1. Consider reducing the valve size and using a reducer in the piping  
This is the most cost-effect solution for T-body styles

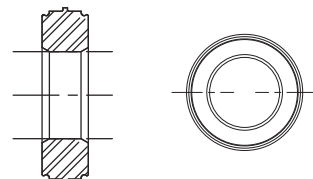

Reduced-Seat Insert 4.0/2.5

2. For cross-flow bodies, a reduced-seat option can be selected.

# WR61/WR63 Over-Pressure Valve Pressure Rise

Utilizing either Air-to-Rise or Air-to-Lower adjustable-spring actuators respectively

4" Diameter Actuator

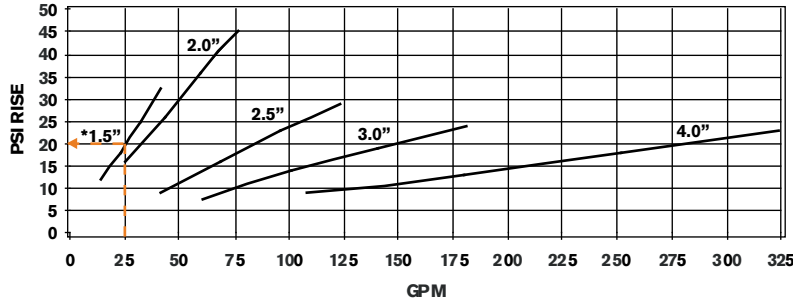

**WR61T 1.5" 4RHAR Actuator**

Relief @ 25 gpm will produce 20psi added pressure rise.  
(See notes below)

**Reseating Pressure:**

Total relief line pressure must drop by 20 psi for reseating.  
(See table below)

5" Diameter Actuator

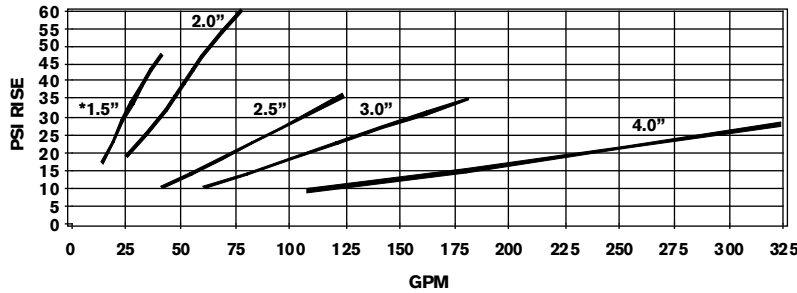

**WR63CD 4.0/2.5 6RHAL Actuator**

Relief @ 115 gpm adds 45 psi pressure rise with the 2.5" plug.  
(See notes below)

**Reseating Pressure:**

Total relief line pressure must drop by 18 psi for reseating.  
(See table below)

6" Diameter Actuator

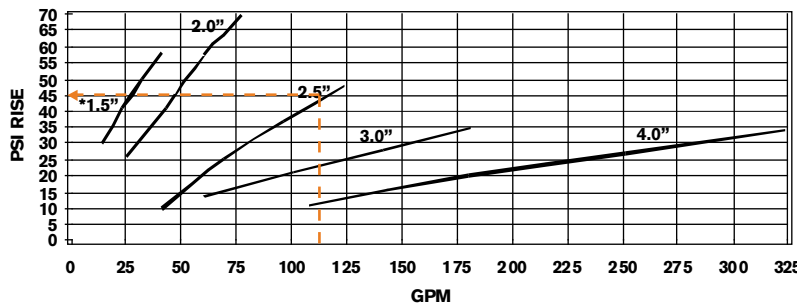

\* Valve Seat Size

Pressure rise and reseating values are estimated based on water at 70° F. Results can vary subject to flow conditions and product properties.

NOTE: Not for use as an ASME-coded relief valve.

**Chart Guide**

1. Locate curve for selected actuator size and valve seat size.
2. Where relief flow rate intersects curve, determine pressure rise.
3. Add pressure-rise to relief-pressure and relief-path line-pressure loss, elevation loss, destination pressure etc. For estimated total pressure during relief.
4. Use reseat pressure to gauge minimum differential between set pressure and normal operating pressure.

VALVE SEAT SIZE (INCHES)	RESEATING PRESSURE	
	REDUCTION IN PRESSURE FROM SET PRESSURE (PSI)*	
	WR61	WR63
1.5" (38)	20	30
2" (51)	12	22
2.5" (64)	8	18
3" (76)	5	15
4" (102)	5	15

## WR61 / WR63 Over-Pressure Valve Pressure Setting

### Maximum Holding Pressure\* Per Valve Size From W61 Valve Chart

PLUG SIZE	ACTUATOR SIZE		
	4" HAR	5" HAR	6" HAR
1.5"	177	378	602
2.0"	99	212	338
2.5"	64	136	216
3.0"	44	94	150
4.0"	25	54	87

### Pressure\* Change Per Turn of Adjusting Screw

PLUG SIZE	ACTUATOR SIZE		
	4RHAR	5RHAR	6RHAR
1.5"	24	40	82
2.0"	13	23	46
2.5"	9	15	29
3.0"	6	10	20
4.0"	3	6	12

Actual pressure change per turn of adjusting screw may be different due to variations between springs.

### Maximum Holding Pressure\* Per Valve Size From W63 Valve Chart

PLUG SIZE	ACTUATOR SIZE		
	4" HAL	5" HAL	6" HAL
2.0"	114	244	323
2.5"	69	147	195
3.0"	46	99	131
4.0"	24	52	68

### Pressure\* Change Per Turn of Adjusting Screw

PLUG SIZE	ACTUATOR SIZE		
	4RHAL	5RHAL	6RHAL
2.0"	16	26	44
2.5"	9	16	27
3.0"	6	11	18
4.0"	3	6	9

Actual pressure change per turn of adjusting screw may be different due to variations between springs.

## Seat Options

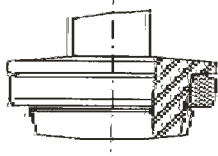
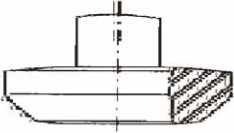
Seat Type	Maximum Temperature	Application	Series
 <p>TEF-FLOW™ "P" (TFP)</p>	280°F (137°C)	High Temp High Pressure	WR60 WR80
 <p>Metal (M)</p>	375°F (190°C)	High Pressure High Flow Large Particulate	WR60 WR80

For higher temperature applications than those listed, please consult the factory.

\*Operating conditions such as flow rate and pressure must be considered when operating near max. temperature rating.

## Control Options

### WR63 Only



#### Features

- Transparent Control Top keeps all electrical components visible.
- Maintainable, designed with the user in mind, making assembly and troubleshooting worry free and easy.
- Waukesha Cherry-Burrell uses the industry's most widely recognized electrical components, so access to off the shelf replacement parts is easy, ensuring quick delivery and less down time.
- NEMA 4x (IP64)



New Set & Forget Control Top

#### Connector Options

- S/O Cord Grip for hard wire (std)
- Quick Disconnect Pin Connectors

#### Interface Options

- ASi Field Bus Card
- Device Net Field Bus Network Card

#### Position Indication

- Set & Forget Switch
- Inductive Proximity Switches 20-140V AC/DC, 2-Wire (Std)
- Microswitches 24VDC, 110VAC
- Intrinsically safe options 5-24VDC

#### Solenoid Valves

- 24VDC or 110V

### WR61 Only

#### Position Indication:

- Yoke mount proximity switch
- (1) or (2) inductive proximity switches, 24VDC/110VAC 2-wire
- Intrinsically safe options

## Port Options

W Butt weld

S S Line

I I Line (female - 15I)

14I I Line (male - 14I)

B Bevel Seat (male threaded end)

F Flange

Q Q Line

D DIN 11851 405 Thread

A Aseptic I-Line (15NI)

For mixed connection types, specify in order of port #.

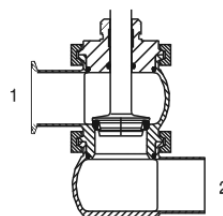

Example:

W61-TS-SW

# Website

For technical details on products and services available from SPX Flow Technology contact us at [www.spxft.com](http://www.spxft.com).

Download specific technical product information including:

- Brochures
- Data sheets
- Maintenance Manuals

## Other Waukesha Cherry-Burrell Products:



Mix Proof  
Valves



PD Pumps



Centrifugal  
Pumps



Votator®  
Scraped Surface  
Heat Exchangers

**ISO 9001  
CERTIFIED**



**SPX**®

Your local contact:



SPX Flow Technology  
611 Sugar Creek Road  
Delavan, WI 53115

Phone: (262)728-1900 or (800)252-5200 Fax: (262)728-4904 or (800)252-5012

E-mail: [wcb@spx.com](mailto:wcb@spx.com)

For more information about our worldwide locations, approvals, certifications, and local representatives, please visit [www.spxft.com](http://www.spxft.com) or [www.gowcb.com](http://www.gowcb.com).

SPX Corporation reserves the right to incorporate our latest design and material changes without notice or obligation.

Design features, materials of construction and dimensional data, as described in this bulletin, are provided for your information only and should not be relied upon unless confirmed in writing.

Issued: 10/2010 DS-1224

Copyright © 2009, 2010 SPX Corporation