

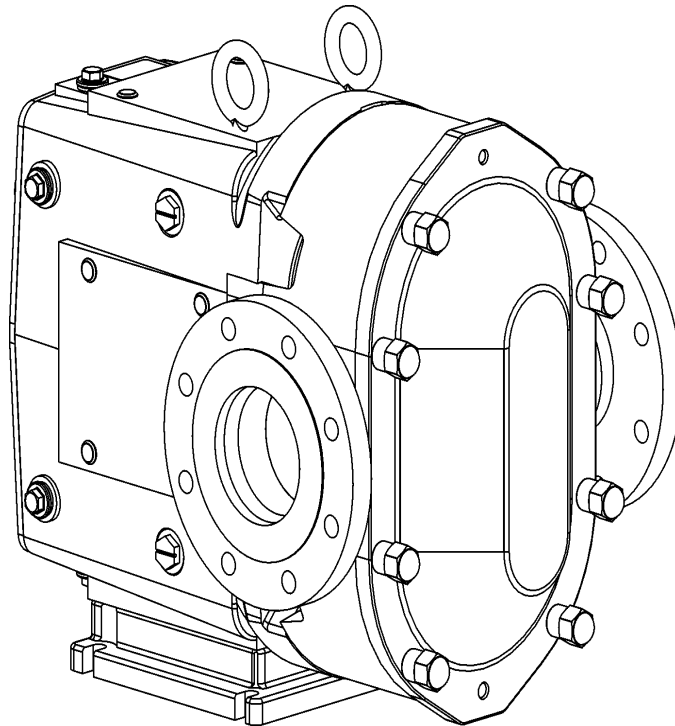

Waukesha Cherry-Burrell

A Unit of SPX Process Equipment

Read and understand this manual prior to installing,
operating or maintaining this pump.



Effective Date:
September 2005

Waukesha Pumps SP UNIVERSAL II SERIES

OPERATION
MAINTENANCE
& PARTS LIST

SAFETY

Warnings, cautions and notes are contained in this manual. To avoid serious injury and/or possible damage to equipment, pay attention to these messages.

WARNING Hazards or unsafe practices which COULD result in severe personal injury or death and how to avoid it.

CAUTION Hazards or unsafe practices which COULD result in minor personal injury or product or property damage.

NOTE Important information pertaining directly to the subject.
(Information to be aware of when completing the task.)

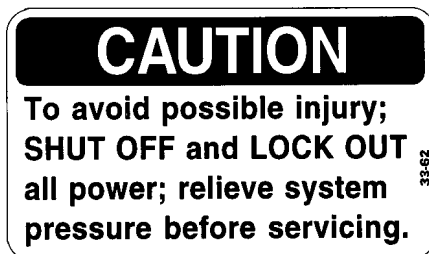
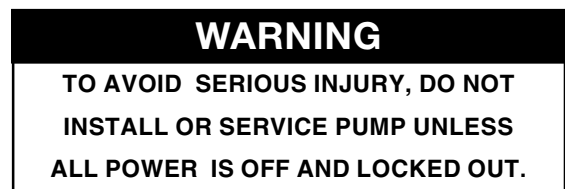
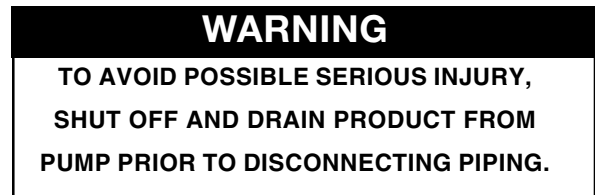

REPLACEMENT LABEL
See Page 61



REPLACEMENT LABEL
See Page 61

Read and understand this manual prior to installing, operating or maintaining this pump.

TABLE OF CONTENTS

SECTION	Page	SECTION	Page
Safety	1	Shims - All Models	26
I Receiving and Warranty	3	Shaft Installation (All Models).....	26
Factory Inspection	3	Bearing Retainer Adjustment	27
Receiving Inspection	3	Rear Seal Assembly	27
Loss or Damage	3	Timing Gear and Cover Assembly	28
Introduction	5	Proper Clearances	29
II Installation	4-9	Back Face	29
Basic Dimensions	4	Rotor to Body	29
III Start-up Check List	10	Front Face	29
IV Troubleshooting a Pump System	11-14	Seals	30
V Operation	15	Basic Seal Assembly	31
Lubrication	15	Fluid Head Assembly	32
VI Maintenance	16	X Reference Tables .	
Visual Checks	16	Table 1. Standard Rotor Clearance	33
Feel Checks	17	Table 2. Assembly Torque Values	33
Annual Maintenance	18	Wrench Sizes	33
VII Factory Reconditioning	19	Table 3. Suggested Shims	33
VIII Disassembly Procedures		Table 4. Hydraulic Press Tonnage	33
Fluid Head Removal	20	XI Universal II Parts Listing	
Cover Removal	20	O-ring Index	34
Rotor Removal	20	Complete Pump Parts Listing	35
Shaft, Bearings and Gear Removal	21-23	Special Ordering Note	
IX Assembly Procedures		Optional Pump Features	36
Shaft Assembly		Illustrated Parts Lists	
Front Bearing	24	Standard Pumps and Stainless Steel Pumps	
Rear Bearing, All Models	25	Model 006U2	36-37
Gear Case Assembly	26	Model 015U2	38-39
		Model 018U2	40-41
		Model 030U2	42-43
		Model 045U2	44-45
		Model 060U2	46-47
		Model 130U2	48-49
		Model 180U2	50-51
		Model 220U2	52-53
		Model 320U2	54-55
		Mechanical Seals	56-60
		Warning Label Replacement	61
		Parts Ordering	62
		Equipment Information	
		How to Order Parts	
		How to Return Parts	

SECTION I

RECEIVING AND WARRANTY

WAUKESHA CHERRY-BURRELL WARRANTY

Seller warrants its products to be free from defects in materials and workmanship for a period of one (1) year from the date of shipment. This warranty shall not apply to products which require repair or replacement due to normal wear and tear or to products which are subjected to accident, misuse or improper maintenance. This warranty extends only to the original Buyer. Products manufactured by others but furnished by Seller are exempted from this warranty and are limited to the original manufacturer's warranty.

Seller's sole obligation under this warranty shall be to repair or replace any products that Seller determines, in its discretion, to be defective. Seller reserves the right either to inspect the products in the field or to request their prepaid return to Seller. Seller shall not be responsible for any transportation charges, duty, taxes, freight, labor or other costs. The cost of removing and/or installing products which have been repaired or replaced shall be at Buyer's expense.

Seller expressly disclaims all other warranties, express or implied, including without limitation any warranty of merchantability of fitness for a particular purpose. The foregoing sets forth Seller's entire and exclusive liability, and Buyer's exclusive and sole remedy, for any claim of damages in connection with the sale of products. In no event shall Seller be liable for any special consequential incidental or indirect damages (including without limitation attorneys' fees and expenses), nor shall Seller be liable for any loss of profit or material arising out of or relating to the sale or operation of the products based on contract, tort (including negligence), strict liability or otherwise.

FACTORY INSPECTION

Each WAUKESHA pump is shipped completely assembled, lubricated and ready for use. (See OPERATION on page 15). The WAUKESHA pump is a precision product, designed to provide long, trouble-free service in a properly designed system with normal maintenance.

RECEIVING INSPECTION

Ports are rubber capped at the factory to keep out foreign objects. If covers are missing or damaged, a thorough inspection of fluid head, by removing pump cover, is recommended. Be sure pumping head is clean and free of foreign material before rotating shaft.

LOSS OR DAMAGE

If your pump has been lost or damaged in transit, file a claim at once with the delivering carrier and ask for an Inspector to call. The carrier has signed the Bill of Lading acknowledging that the shipment has been received from us in good condition.

We will of course assist you in every way in collecting claims for loss, or damage, however, we are not responsible for the collection of claims or replacement of material.

WARRANTY

Please read the Warranty statement to correctly determine if you have a claim. In warranty claims you must have a "Returned Goods Authorization" (RGA) from the manufacturer before any returns will be accepted. Your Distributor will help you in a warranty problem. (See back pages for Information required)

SECTION II INSTALLATION

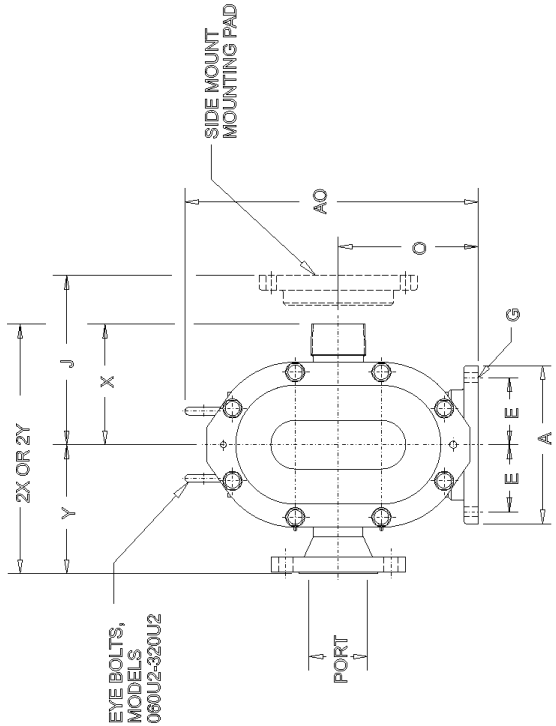
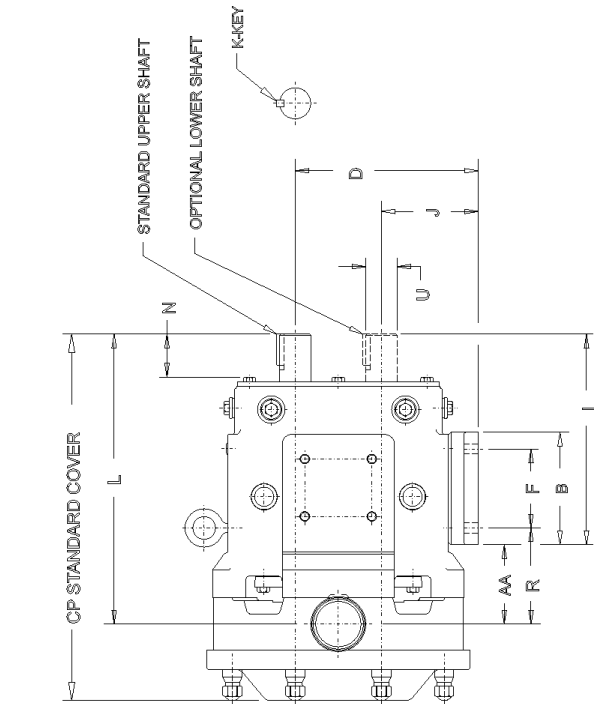

**WAUKESHA SP UNIVERSAL 2 PUMP
DIMENSIONS WITH MALE NPT OR FLANGED PORTS**

MALE NPT CONN. 150 OR 300 LB FLANGE CONN.

RUMP MODEL	A	AA	AO	B	CP	D	E	F	G	G1	I	J	K	L	N	O	PORT SIZE	R	U 1,000 LBS	X	2X	Y	2Y	WEIGHT LBS/KG
SP-006U2	IN 4.75	1.95	8.30	3.75	11.71	5.50	1.94	2.31	.41, SLOT	5/16-18x.62	7.66	2.93	.1875	9.61	2.00	4.21	1"	2.79	.875	4.06	8.11	4.17	8.33	55
	MM 121	50	211	95	297	140	49	59	10, SLOT	-	194	74	4.763	244	51	107	-	71	22.23	103	206	106	212	25
SP-016U2	IN 4.75	1.95	8.30	3.75	11.71	5.50	1.94	2.31	.41, SLOT	5/16-18x.62	7.66	2.93	.1875	9.61	2.00	4.21	1 1/2"	2.79	.875	4.06	8.11	4.67	9.33	60
	MM 121	50	211	95	297	140	49	59	10, SLOT	-	194	74	4.763	244	51	107	-	71	22.23	103	206	119	237	27
SP-018U2	IN 4.75	2.18	8.30	3.75	12.37	5.50	1.94	2.31	.41, SLOT	5/16-18x.62	7.66	2.93	.1875	10.49	2.00	4.21	1 1/2"	3.02	.875	4.06	8.11	4.17	8.33	60
	MM 121	55	211	95	314	140	49	59	10, SLOT	-	194	74	4.763	288	51	107	-	77	22.23	103	208	106	212	27
SP-030U2	IN 6.25	2.78	10.29	4.25	14.49	6.86	2.31	2.56	.41, SLOT	3/8-16x.62	8.83	3.56	.25	11.61	2.32	5.21	1 1/2"	3.84	1.250	4.76	9.52	4.87	9.74	120
	MM 159	71	261	108	368	174	69	65	10, SLOT	-	224	90	6.35	295	59	132	-	98	31.75	121	242	124	247	54
SP-045U2	IN 8.25	3.86	15.31	5.87	18.59	9.56	3.50	4.12	.53	1/2-13x.88	10.99	5.06	.375	14.86	2.25	7.31	2"	4.73	1.625	5.98	11.95	6.79	13.57	120
	MM 210	98	389	149	472	243	89	106	13	-	279	129	9.525	377	57	186	-	120	41.28	152	304	172	345	54
SP-060U2	IN 8.25	4.14	15.31	5.87	19.14	9.56	3.50	4.12	.53	1/2-13x.88	10.99	5.06	.375	15.14	2.25	7.31	2 1/2"	5.01	1.625	6.29	12.57	6.73	13.45	270
	MM 210	105	389	149	486	243	89	105	13	-	279	129	9.525	385	57	186	-	127	41.28	160	319	171	342	122
SP-130U2	IN 8.25	4.78	15.31	5.87	20.15	9.56	3.50	4.12	.53	1/2-13x.88	10.99	5.06	.375	15.77	2.25	7.31	3"	5.65	1.625	6.32	12.64	6.73	13.45	300
	MM 210	121	389	149	512	243	89	105	13	-	279	129	9.525	401	57	186	-	144	41.28	161	321	171	342	136
SP-160U2	IN 8.50	3.45	19.13	9.00	23.26	12.38	3.75	7.25	.53, SLOT	1/2-13x1.00	14.80	6.38	.50	18.25	2.75	9.38	3"	4.20	2.000	7.48	14.95	7.88	15.76	505
	MM 216	88	486	229	591	314	95	184	13, SLOT	-	376	162	12.7	464	70	238	-	107	50.80	190	380	200	400	229
SP-210U2	IN 12.00	3.45	22.38	11.63	27.08	13.88	5.25	8.00	.66	1/2-13x1.00	17.80	6.88	.625	21.24	4.06	10.38	4"	4.70	2.375	8.31	16.82	8.63	17.25	505
	MM 305	88	568	295	688	353	133	203	17	-	452	175	15.88	539	103	264	-	119	60.45	211	422	219	438	229
SP-220U2	IN 8.50	3.69	19.13	9.00	24.00	12.38	3.75	7.25	.53, SLOT	1/2-13x1.00	14.80	6.38	.50	18.49	2.75	9.38	4"	4.44	5.98	7.57	15.14	7.88	15.76	505
	MM 216	94	486	229	610	314	95	184	13, SLOT	-	376	162	12.7	470	70	238	-	113	50.80	192	385	200	400	229
SP-320U2	IN 12.00	3.84	22.38	11.63	27.66	13.88	5.25	8.00	.66	1/2-13x1.00	17.80	6.88	.625	21.63	4.06	10.38	4"	5.09	2.375	-	-	8.00	16.00	850
	MM 305	97	568	295	703	353	133	203	17	-	452	175	15.88	549	103	264	-	129	60.45	-	-	203	406	386

NOTE: DIMENSIONS "X" AND "2X" APPLY FOR NPT PORTS (EXCEPT FOR 320U2) & "Y" AND "2Y" APPLY FOR FLANGED PORTS.

INTRODUCTION

Waukesha Universal II pumps are positive displacement, low slip design with larger diameter shafts for greater strength and stiffness, mounted on a heavy duty bearing frame (stainless steel option) and double tapered bearings.

- Rotor hubs are sealed from product zone; rotors are locked with belleville washers and torqued nuts and rotate securely in either direction. (Bi-directional)
- "88" alloy rotors are standard. Single wing rotors and 316 material, optional.

- Seal flush standard. Seal areas are interconnected to improve circulation and draining of seal flush fluid. Steam-In-Place is available with a special rotor option.
- Mechanical seals are standard. O-ring seals optional.
- Optional free draining pump body and cover when mounted on its side.
- Optional CIP capability, with mechanical or O-ring seals.

INSTALLATION

PUMP INSTALLATION

The installation of your Waukesha pump and its piping system should follow the practices described to give optimum performance, and be in accordance with local codes and restrictions.

All system equipment, such as motors, sheaves, drive couplings, speed reducers, etc., must be properly sized to insure satisfactory operation of your Waukesha pump within its limits.

CAUTION: Waukesha pumps are positive displacement, low slip design and will be severely damaged if operated with closed valves in discharge or inlet lines. Pump warranty is not valid for damages caused by a hydraulic overload from operation or start-up with a closed valve in the system.



WARNING

Full coupling guards must be installed to isolate operators and maintenance personnel from rotating components. Coupling guards are provided with Waukesha pumps as a part of a complete pump and drive package.

1. Installing the Pump and Drive Unit. Pumps of this type can be mounted on a common base plate with the drive. The unit can be installed in several ways:

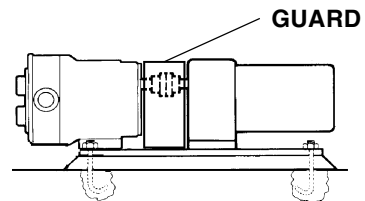

Permanent installation on foundation with bolts and grout. (Level unit before grouting.)

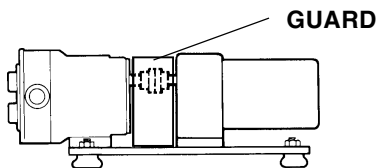

Leveling and/or vibration isolation pads.

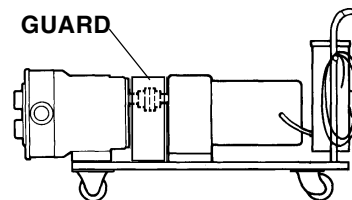

Portable bases-for movement to different locations. Many Commercial types are available.

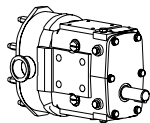

Bottom Shaft Mount

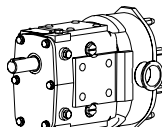

Top Shaft Mount

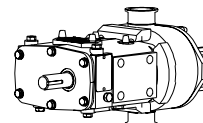

Sidemount (Requires Free Drain body option)

INSTALLATION

2. Good Piping Practice.

All piping to the pump should be supported independently, to minimize the forces exerted on the pump. Such forces can cause misalignment of pump parts and lead to excessive wear of rotors, bearings and shafts.

NOTE: Pump dimensions and pump weights are on page 4.

A. Piping support:

Weight of piping and fluid-support piping independently with hangers or pedestals.



Thermal expansion of piping can cause tremendous forces. Use thermal expansion joints to minimize forces on pump.

B. Flexible joints can also be used to limit the transmission of mechanical vibration. Anchor free ends of any flexible hose in system.

Piping Layout

C. Inlet side: Slope piping up to inlet to avoid air pocket.

D. Inlet side-use check valves to keep inlet line full, particularly with low viscosity fluids, and in start-stop operation.

E. Inlet Vacuum Service-use check valve on outlet side.

- Prevents backflow (air or fluid).
- Facilitates initial start-up (minimizes differential pressure pump must supply to start flow).

F. "Isolation" Valves-permit pump maintenance and removal safely and without emptying entire system.

G. Relief Valve

To protect the pump and piping system against excessive pressure, a relief valve should be installed. An integral relief valve, designed to bypass the fluid internally from the pump outlet to the inlet, should not be used on applications where the discharge must be closed for more than a few minutes. Prolonged operation of the pump with closed discharge will cause heating of the fluid circulating through the relief valve. When such operation is necessary, the relief valve, whether integral, attachable, or line-mounted, should discharge externally through piping connected to the fluid source, or if that is not practical, into the inlet piping near the source.

WARNING

TO AVOID SERIOUS INJURY, DO NOT INSTALL OR SERVICE PUMP UNLESS ALL POWER IS OFF AND LOCKED OUT.

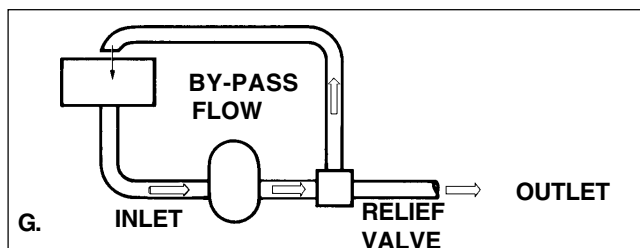
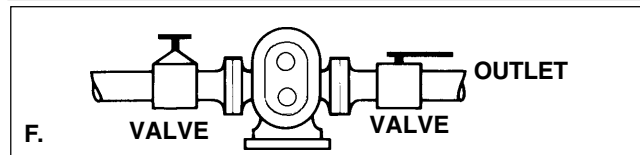
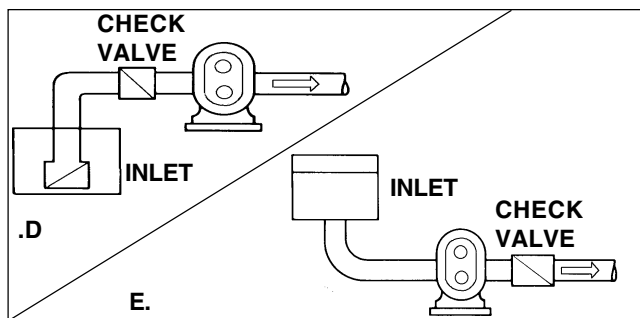
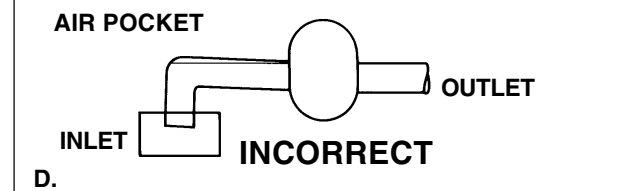
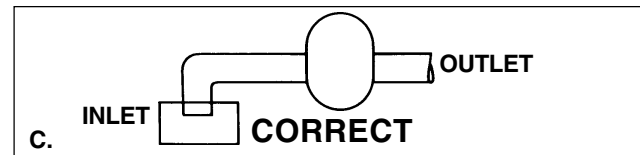
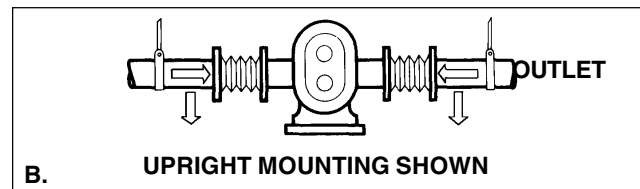
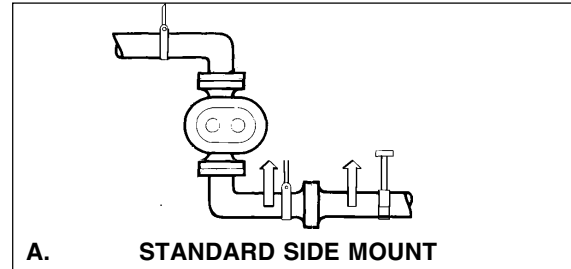

INSTALLATION

Inlet Side-Strainers and Traps.

Inlet side strainers and traps can be used to prevent pump damage from foreign matter. Selection must be carefully made as clogging can easily occur, restricting the inlet, causing cavitation and flow stoppage.

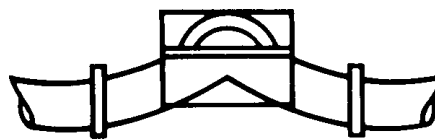

MAGNETIC TRAP

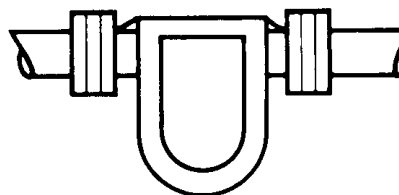

STRAINER

Pressure Gauges

Pressure and Vacuum gauges provide the easiest way to tell you something about the pump operation.

- Normal or abnormal pressures
- Overload conditions
- Indication of flow
- Changes in pump condition
- Changes in system conditions
- Changes in fluid viscosity

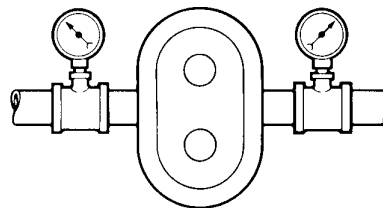

Wherever possible-install gauges!!

3. Alignment of Pump to Drive.

Pumps and drives which are ordered from the factory and mounted on a common base plate are accurately aligned before shipment. The alignment should be rechecked after the complete unit has been installed and the piping completed. Periodic rechecking is advisable during the pump service life.

In-line Drives. For initial pump installation, and for rechecking alignment, the following steps are advised:

Use a flexible coupling to connect the drive to the pump. Many different types are available, including couplings with slip or overload provision.

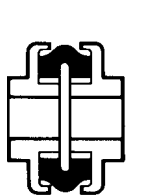

RUBBER CUSHIONED

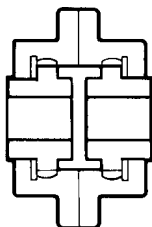

GEAR TYPE

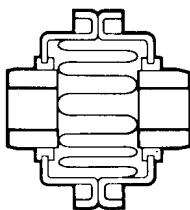

FLEXIBLE MEMBER

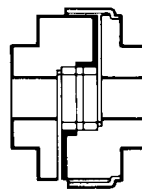

DETENT

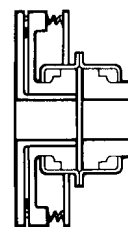

SLIP OVERLOAD

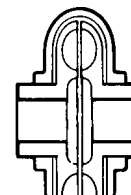

FLUID

A flexible coupling is used to compensate for end play and small differences in alignment. The pump and drive shaft should be aligned as closely as is possible.

WARNING

TO AVOID SERIOUS INJURY, DO NOT INSTALL OR SERVICE PUMP UNLESS ALL POWER IS OFF AND LOCKED OUT.

INSTALLATION

Check angular alignment:

Using feeler gauges, or taper gauges. Adjust to get equal dimension at all points. At the same time set space between coupling halves to manufacturer's recommended distance.

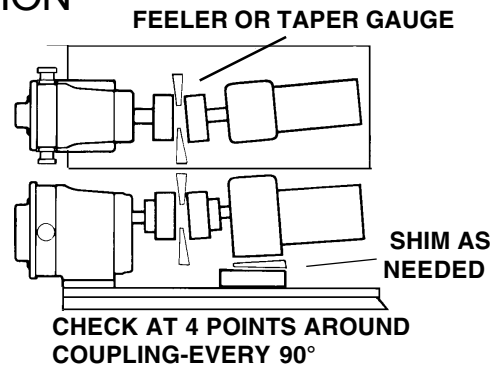

Check parallel misalignment: Use straight edges and shims:

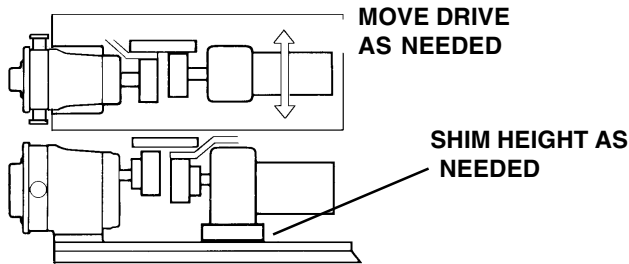

After piping is complete, and drive and couplings are aligned, turn pump shaft manually to see if it turns freely without binding.

Check rotation direction of drive to see that pump will rotate in proper direction. ("Liquid End" of pump is shown below.)

Warning Note: Covers have been removed for illustration purposes only. The pump cannot be operated with the cover removed.

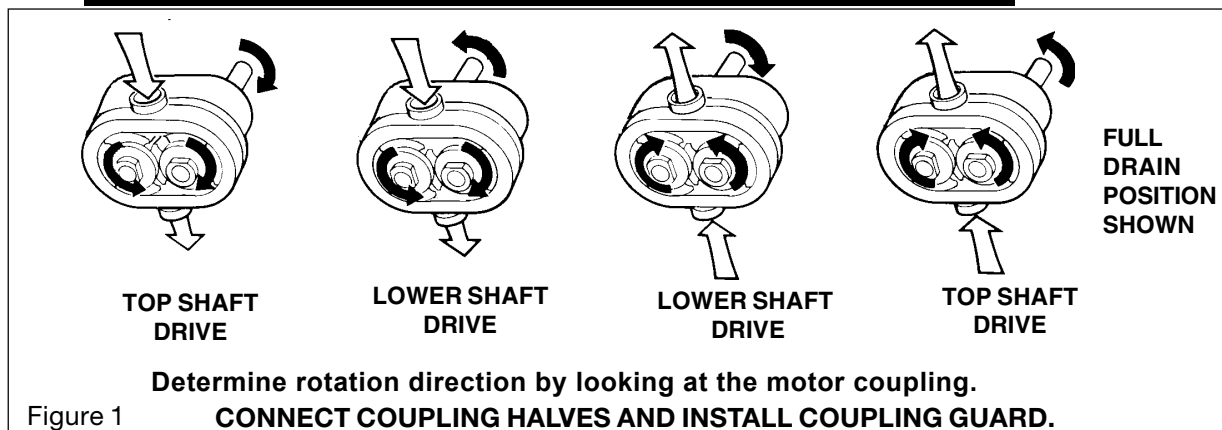

Aligning belt and chain drives. Using straight-edges and visual check:

MOVE DRIVE TO CORRECT ANGULAR AND PARALLEL MISALIGNMENT.

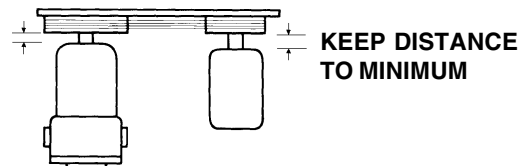
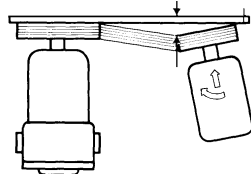

After piping is complete and before belts are installed, **turn pump shaft manually** to see that it turns freely. Check rotation direction of pump to see that pump will rotate in proper direction (see figure 1) Install belts and tension them correctly. Install belt guard.

INSTALLATION

Flushing Connections

NOTE: Flushing media enters the bottom side and discharges from the top side. Be sure flush water is flowing out discharge line. *Flushing holes are threaded for 1/8 NPT.*

Low Pressure Flush (Standard recommendation)

- Set flow rate of approximately 1/4 GPM for most applications. For high temperature applications, increase flow.
- Flushing media is restricted on inlet side and has free flow to drain on outlet side.

High Pressure Flush

This method is good for abrasive applications and products that tend to "set" on seal faces.

- Set flow rate of approximately 1/4 GPM for most applications. Solenoid is recommended to stop flushing when pump is stopped. Restriction and pressure gauge is at discharge end. **Do not exceed 30 PSI with standard seals.**

FLUSH OUT

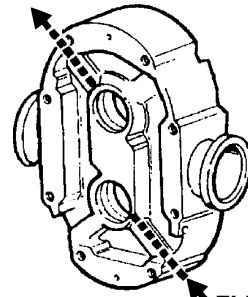

FLUSH IN

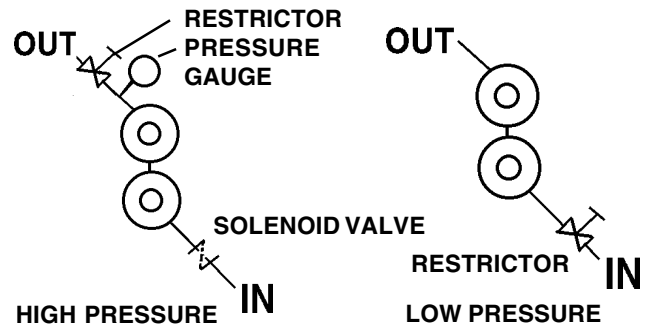

SECTION III

START-UP CHECK LIST

The Waukesha Pump is a positive displacement pump and thus can develop very high pressures. To protect lines, equipment and personnel, certain precautions must be taken.

1. Review Section II, page 7, particularly "Relief Valves". Install relief valves if needed.
2. Check that piping and pump are clean and free of foreign material, such as welding slag, gaskets, etc. **Do not use pump to flush system.**
3. See that all piping connections are tight and leak-free. Where possible, check system with "non-hazardous" fluid.
4. Check to see that pump and drive are lubricated. See Section V, page 15. Check Drive Lubrication Instruction.
5. Check that all guards are in place and secure.
- 6 Seals: Double mechanical and double O-ring seals with flushing require adequate supply and flow of clean flushing fluids.
7. See that all valves are open on discharge system, and that free flow path is open to destination.
8. See that all valves are open on inlet side, and that fluid can reach pump.
9. Check direction of pump and drive rotation. (See page 8)
10. Start pump drive. Where possible, start at slow speed, or jog.

Check to see that liquid is reaching pump within several minutes. If pumping does not begin and stabilize, check items under "No Flow" or "Insufficient Flow" in Section IV, (Page 11) Troubleshooting a Pumping System.

SECTION IV

TROUBLESHOOTING A PUMPING SYSTEM

Once a pump is properly selected and installed in a system, operation should be trouble free. However, in existing systems, or as pump and system conditions change, problems may develop. Following are some troubleshooting hints to help identify and solve problems.

WARNING

**TO AVOID SERIOUS INJURY, DO NOT
INSTALL OR SERVICE PUMP UNLESS
ALL POWER IS OFF AND LOCKED OUT.**

WARNING

**TO AVOID POSSIBLE SERIOUS INJURY,
SHUT OFF AND DRAIN PRODUCT FROM
PUMP PRIOR TO DISCONNECTING PIPING.**

Problem	Probable Causes	Solutions
No flow, pump not turning	Drive motor not running	Check resets, fuses, circuit breakers
	Keys sheared or missing	Replace
	Drive belts, power transmission components slipping or broken	Replace or adjust
	Pump shaft, keys, or gears sheared	Inspect: replace parts
No flow, pump not priming	Valve closed in inlet line	Open valve
	Inlet line clogged or restricted	Clear line, clean filters, etc.
	Air leaks due to bad seals or pipe connections	Replace seals; check lines for leakage (can be done by air pressure or by filling with liquid and pressurizing with air)
	Pump speed too slow	Increase speed. Filling inlet lines with fluid may allow initial start-up. Foot valve may solve start-up problems permanently.
	Liquid drains or siphons from system during off periods	Use foot valve or check valves

TROUBLESHOOTING

Problem	Probable Causes	Solutions
No flow, pump not priming	"Air" lock. Fluids which "gas off", or vaporize, or allow gas to come out of solution during off periods	Manual or automatic air bleed from pump or lines near pump
	Extra clearance rotors, worn pump	Increase pump speed, use foot valve to improve priming
	Net inlet pressure available too low	Check NIPA, NIPR~, recalculate system. Change inlet system as needed.
	On "Vacuum" inlet system: On initial start-up, atmospheric "blow back" prevents pump from developing enough differential pressure to start flow.	Install check valve in discharge line
Insufficient flow	Speed too low to obtain desired flow	Check flow-speed curve
	Air leak due to bad seals or pipe connections	Replace seals, check inlet fittings.
Fluid vaporization ("starved" pump inlet)	Strainers, foot valves, inlet fittings or lines clogged	Clear lines. If problem continues, inlet system may require change
	Inlet line size too small, inlet line too long. Too many fittings or valves. Foot valve, strainers too small .	Increase inlet line size. Reduce length, minimize direction and size changes, reduce number of fittings.
	NIPA too low	Raise liquid level in source tank
	NIPA too low	Increase by raising or pressurizing source tank

NIPA - Net Inlet Pressure Available at Pump
NIPR - Net Inlet Pressure Required by Pump

TROUBLESHOOTING

Problem	Probable Causes	Solutions
Fluid vaporization ("starved" pump inlet)	NIPA too Low	Select larger pump size with smaller NIPR
	Fluid viscosity greater than expected	Reduce pump speed and accept lower flow, or change system to reduce line losses.
	Fluid temperature higher than expected (vapor pressure higher)	Reduce temperature, reduce speed and accept lower flow or change system to increase NIPA
Insufficient flow. Fluid being bypassed somewhere	Flow diverted in branch line, open valve, etc.	Check system and controls
Insufficient flow. High slip	Hot (HC) or extra clearance rotors on "cold" fluid, and/or low viscosity fluid	Replace with standard clearance rotors
	Worn pump	Increase pump speed (within limits). Replace rotors, recondition pump.
	High pressure	Reduce pressure by system changes
Noisy operation	Cavitation	
	High fluid viscosity, High vapor pressure fluids, High temperature	Slow down pump, reduce temperature, change system
	NIPA less than NIPR see Engineering Manual	To increase NIPA or reduce NIPR,
	Air or gas in fluid	
	Leaks in pump or piping	Correct leaks
	Dissolved gas or naturally aerated products	Minimize discharge pressure. Also see "Cavitation" above.
	•Mechanical noises Rotor to body contact	
	Improper assembly	Check clearance with shims. See page 26.

TROUBLESHOOTING

Problem	Probable Causes	Solutions
Noisy operation	<ul style="list-style-type: none"> • Rotor to body contact Distortion of pump due to improper piping installation. 	Reassemble pump or reinstall piping to assure free running
	Pressure higher than rated	Reduce pressure if possible
	Worn bearing	Rebuild with new bearings. Lubricate regularly
	Worn gears	Rebuild with new gears. Lubricate regularly
	<ul style="list-style-type: none"> • Rotor to rotor contact Loose or mis-timed gears. twisted shaft, sheared keys. worn splines 	Rebuild with new parts
	<ul style="list-style-type: none"> • Drive component noise-gear trains, chains, couplings, bearings. 	Repair or replace drive train
Pump requires excessive power (overheats, stalls. high current draw, breakers trip)	<ul style="list-style-type: none"> • Higher viscous losses than expected 	If within pump rating, increase drive size
	<ul style="list-style-type: none"> • Higher pressure than expected 	Reduce pump speed, increase line sizes
	<ul style="list-style-type: none"> • Fluid characteristics Fluid colder than expected. viscosity high 	Heat fluid. insulate or heat trace lines. Use pump with more running clearances.
	Fluid sets up in line and pump during shut down	Insulate or heat trace line. Install "soft start" drive. Install recirculating bypass system. Flush with other fluid.
	Fluid builds up on pump surfaces (example. latex, chocolate. fondants)	Use pump with more running clearance
	"Short" pump service life	High corrosion rate
Pumping abrasives		Larger pumps at slower speeds, can help
Speeds and pressures higher than rated		Reduce speeds and pressures by changes in system
Worn bearings and gears due to lack of lubrication		Set up and follow regular lubrication schedule
Misalignment of drive and piping. Excessive overhung load or misaligned couplings.		Check alignment of piping. Check drive alignment and loads. (Page8)

SECTION V OPERATION

Normal operation covers a speed range of 0-600 RPM and pressure range of 0-200 PSI. Temperature range with standard rotors is -40° to 200° F. and with hot clearance rotors, 180° to 300° F. (For operation at higher temperatures, consult Waukesha Cherry-Burrell.)

See START-UP CHECK LIST (Page 10) and TROUBLESHOOTING (Page 11-14) for additional operation information.

LUBRICATION

The gears are factory lubricated with Micro-Plate No. 140 oil at the quantity shown for top or bottom shaft mounts. If you mount your pump other than top or bottom shaft drive, check oil level.

The bearings are factory greased with Micro-Plate #555 grease.

Change oil every 1000 hours. If pump is installed where moisture and condensation are heavy, change oil more frequently.

Bearings must be greased every 1000 hours or less depending on moisture and condensation conditions. Excess grease will accumulate in the gear case and can be removed through the cleanout hole covered with plastic plug.

NOTE: For hot or cold extremes use appropriate lubricant as shown in the following tables.

OIL
Micro-Plate #140 -10° to 350° F. (-23° to 177° C.)

GREASE
Silicone -20° to 5° F. (-29° to 15° C.) Micro-Plate #555 (5° to 350° F. (-15° to 177° C.)

DRIVE LUBRICATION

Refer to drive manufacturer's manual shipped with unit.

CAUTION

To avoid possible injury;
SHUT OFF and LOCK OUT
all power; relieve system
pressure before servicing.

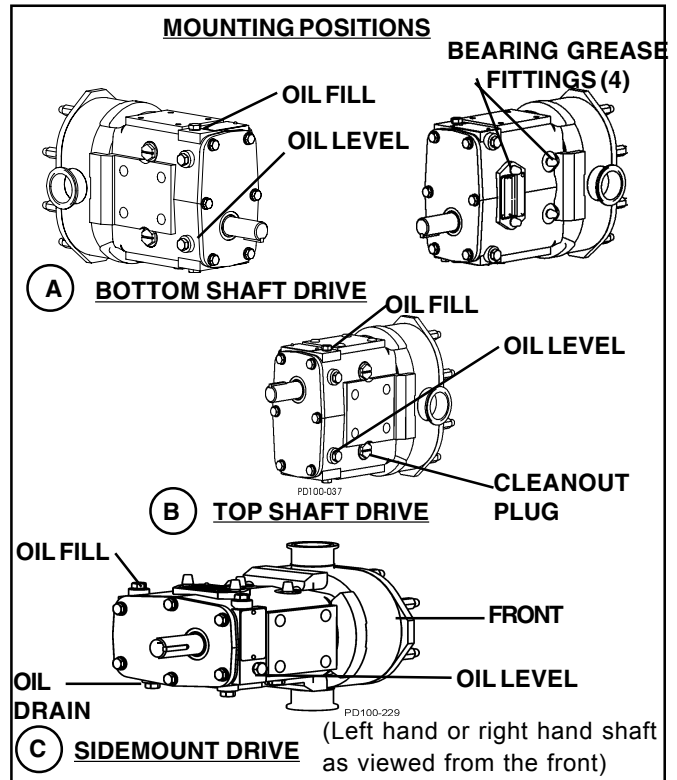

OIL CAPACITY (GEARS)		
MODEL	SHAFT	
	TOP OR BOTTOM	SIDE MOUNT
006, 015, 018	1.3 oz. (40 ml)	3.3 oz. (100 ml)
030	2 oz. (60 ml)	4 oz. (120 ml)
045, 060, 130	6 oz. (170 ml)	9.5 oz. (280 ml)
180, 220	11 oz. (320 ml)	20 oz. (600 ml)
320	17 oz. (500 ml)	44 oz. (1300 ml)

Where possibility of material "setting up" during shut down exists, flushing with solvent or dis-assembly of fluid head and manual cleaning are required.

CIP feature: See Page 9

SECTION VI MAINTENANCE

GENERAL

In the maintenance of pumps it is important to recognize when parts are wearing excessively. Detecting wear in the early stages will let you repair your pump at minimum cost and get it back into operation at the earliest date.

Periodic cleaning and a simple “look-feel” inspection of your pump are recommended as good operating procedures and as a means of detecting signs of trouble at an early stage. They require only a few minutes and may save you an appreciable amount of money.

A more detailed maintenance inspection should be scheduled annually. See ANNUAL MAINTENANCE, Page 18.

The following routine “look-feel” checks are to be made by the system operator during shut-down periods.

WARNING
Disconnect power from pump drive before removing cover.

VISUAL CHECKS

CHECK ROTOR TIPS FOR WEAR AND CLEARANCE

Removal required: Cover, Rotors; see page 20

Indications of metal-to-metal contact between rotor wings means the pump should be repaired or replaced.

1. CHECK ROTOR SHAFTS/KEY FOR WEAR

Cause	Corrective Measure
Worn shaft/key	Replace shaft/key.
Worn rotor keyway	Replace rotor.
Loose or worn gears ...	Replace gears.

(See ASSEMBLY on page 26)

Twisted shaft

Replace shaft.

NOTE: Usually both parts will wear. The cause is operating with a loose rotor nut for an extended period. (See page 24 for key replacement.)

2. CHECK ROTOR HUB END for signs of wear.

(End locks against the shaft shoulder.)

Cause	Corrective Measure
Extended running with loose rotor retaining nuts	Replace rotor or re-shim shaft to maintain back face clearance.

**ROTOR TO ROTOR TIP
CLEARANCE MUST BE
EQUAL ON BOTH SIDES**

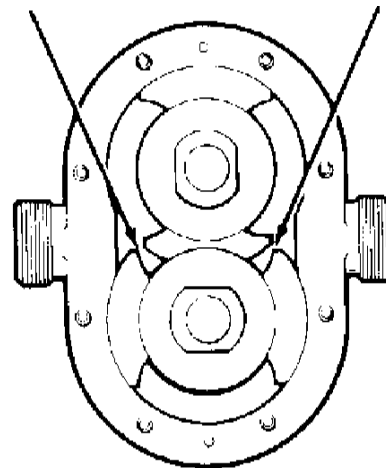

KEYWAY

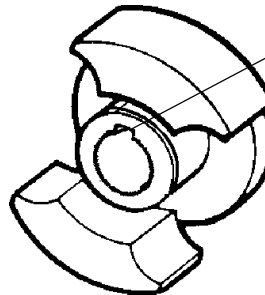

**O-RING
GROOVE
ON HUB**

**HUB END
WEAR**

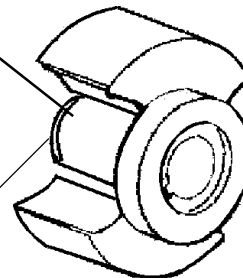

NOTE: Each time rotors are removed the O-rings on the hub must be replaced.

11-28-95

MAINTENANCE

3. CHECK SHAFT SHOULDER for deterioration.

(Rotor hub locates against.)

Cause	Corrective Measure
Loose rotor.....	Re-shim or replace shaft to maintain correct running clearances.

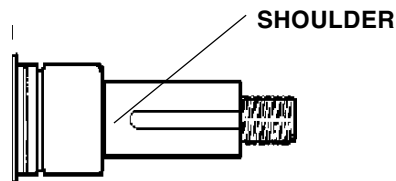

"FEEL" CHECKS

GEAR/BEARING CHECK

Removal required: Fluid Head Assembly and Seals
Page 20 and 31

1. Gear Back Lash - If there is any free movement when rotating either shaft without transmitting motion to other shaft, the back lash is excessive.

Cause	Corrective Measure
Worn gear teeth.....	Replace gear.
Gear loose on shaft	Remove gear and inspect key, keyway and shaft. (See page 21) If all are in good condition, reassemble and retighten gear retaining nuts to specified torque. (See Table 2. Page 33)

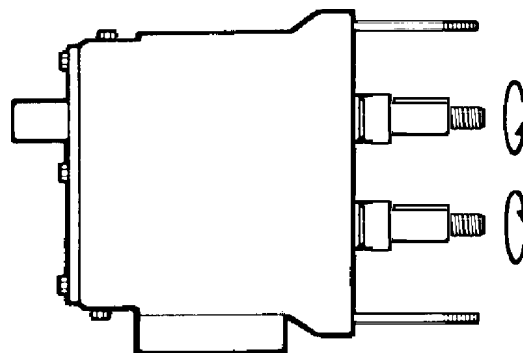

NOTE: Replace oil seal in cover when assembling.

CHECK BEARING CONDITION

Removal required; Fluid Head Assembly and Seals
Pages 20 and 31

2. Bearing Condition - If movement of either shaft can be detected when hand loading the rotor end of the shaft (approximately 30 lbs. force applied as illustrated), bearing may be failing.

Cause	Corrective Measure
Lack of lubricant or high overload.....	Replace bearings and review lubrication schedule. (Page 15) Check for means to reduce hydraulic loads.

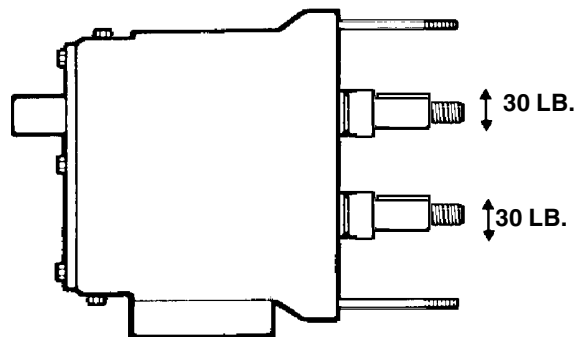
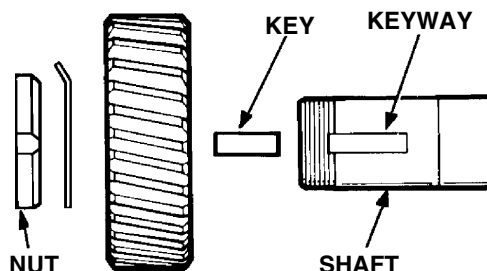

ANNUAL MAINTENANCE

The same general procedures and corrective measures outlined above should be performed and in addition the following preventive maintenance operations should be carried out at this annual checkout period.

WARNING
Disconnect and lock out power from pump drive before performing maintenance.

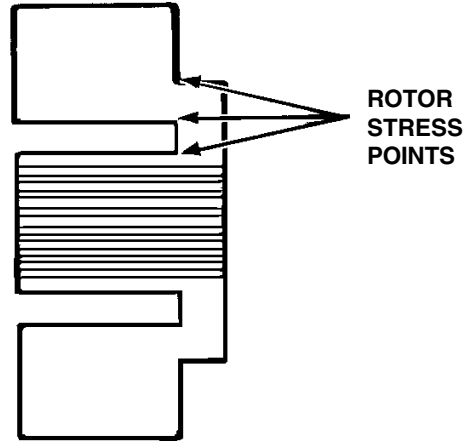
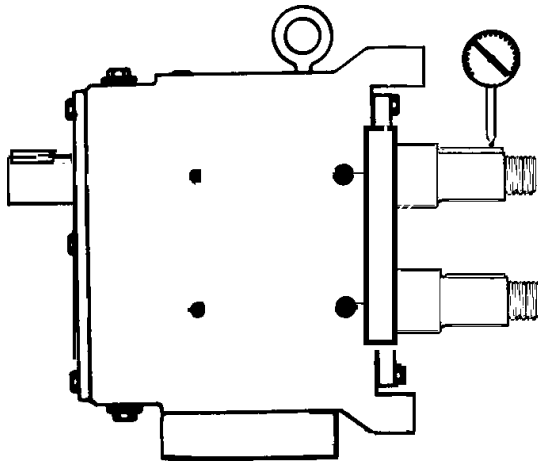

1. Check bearing with a dial indicator for shaft radial play. If deflection is equal to or greater than rotor to body diametrical clearance (see Table 1, Page 33) replace bearings.
2. Remove gear cover and inspect gears for wear, back lash and looseness. Re-torque gear retaining nuts to proper torque. (See Table 2, Page 33)

3. Thoroughly inspect rotors for worn splines, bearing shoulder wear, and stress cracks. Use dye check method to detect any fatigue type cracks at the stress points that may develop into serious trouble.

4. Review performance record on pump and check radial and back face clearances to determine wear and its effect on desired performance. (See Table 1, Page 33) and Section IX (Page 24). An adjustment on operating speed can compensate for wear in some applications. When wear and subsequent performance is objectionable, we suggest you take advantage of our reconditioning program. (See Section VII Page 19)

CAUTION: If bearings or shafts are replaced in the field, extreme care should be exercised to position the shaft, by shimming, to maintain sufficient running clearances between the rotor wing faces and the pump body faces (backface and cover face). Refer to Table 1 (Page 33) and BACKFACE CLEARANCE, Section IX (Page 29). If rotors are slightly out of time, they can be re-timed by shimming the gears.

It is important to hold the same back face dimension for both rotors to avoid crossover interference.

SECTION VII

FACTORY REMANUFACTURING

Waukesha UNIVERSAL pumps are designed to allow them to be factory remanufactured twice and backed with a new pump warranty each time.

Factory remanufactured involves replacement of all worn parts such as shafts, bearings, oil seals, gears, etc.

The pump body and cover are re-machined and new rotors are installed.

The pumps are stamped R-1 or R-2, after the serial number, designating that they have been remanufactured once or twice.

NOTE: *It is advisable to contact the factory and furnish the serial number of any pump being considered for remanufacturing.*

When pumps require remanufacturing it is recommended that they be returned to Waukesha Cherry-Burrell with proper purchase order. Where this is not practical, a "remanufactured" pump may be ordered in advance of the actual return of the pump being replaced.

While a large stock of remanufactured pumps is maintained, normal delivery of four weeks should be anticipated. In these cases an invoice will be issued for the price of a new pump with credit allowed upon receipt of the old pump at the factory so the net cost will be that of a remanufactured pump.

INTERCHANGEABILITY

All new pumps are identified by a serial number on bearing gear case nameplate and stamped on top of pump body. The gear case and body must be kept together as a unit because of back face clearance. The rotors, seals and covers can be interchanged between units.

ALL remanufactured pump parts must be kept together as a unit. These are specially machined and are not interchangeable.

CAUTION: If new body is replaced in the field, it is most important to check back face and front face clearances (See Table 1, Page 33). Re-shim shafts if required to avoid rotor and cover contact. Both rotors must have the same clearance to avoid crossover interference.

SECTION VIII DISASSEMBLY PROCEDURES

WARNING

TO AVOID POSSIBLE SERIOUS INJURY,
SHUT OFF AND DRAIN PRODUCT FROM
PUMP PRIOR TO DISCONNECTING PIPING.



WARNING

Disconnect and lock out all
power from pump drive before
performing service.

FLUID HEAD DISASSEMBLY

(Use these instructions for cleaning disassembly.)
1. Remove cover nuts from cover. Tap cover off threaded rods, dowels and rotor hubs. Remove and inspect O-ring. *Be sure to have adequate support when removing cover, especially on the larger units.*

Use wrench to remove rotor nuts, each containing a washer and two O-rings.

Use a plastic or hardwood bar to lever rotors out. If necessary use a puller. Use care to avoid damage to the rotors with the puller or the bar. Each rotor has an O-ring on the end of the hub.

NOTE: *If pump is not in service, a hardwood or plastic rod placed in the port when removing rotor nuts.*

To remove the body, remove the two socket head cap screws and tap the body off the studs with a plastic mallet.

See Page 31 for Seal Information

Avoid damaging surfaces of the body and rotors.

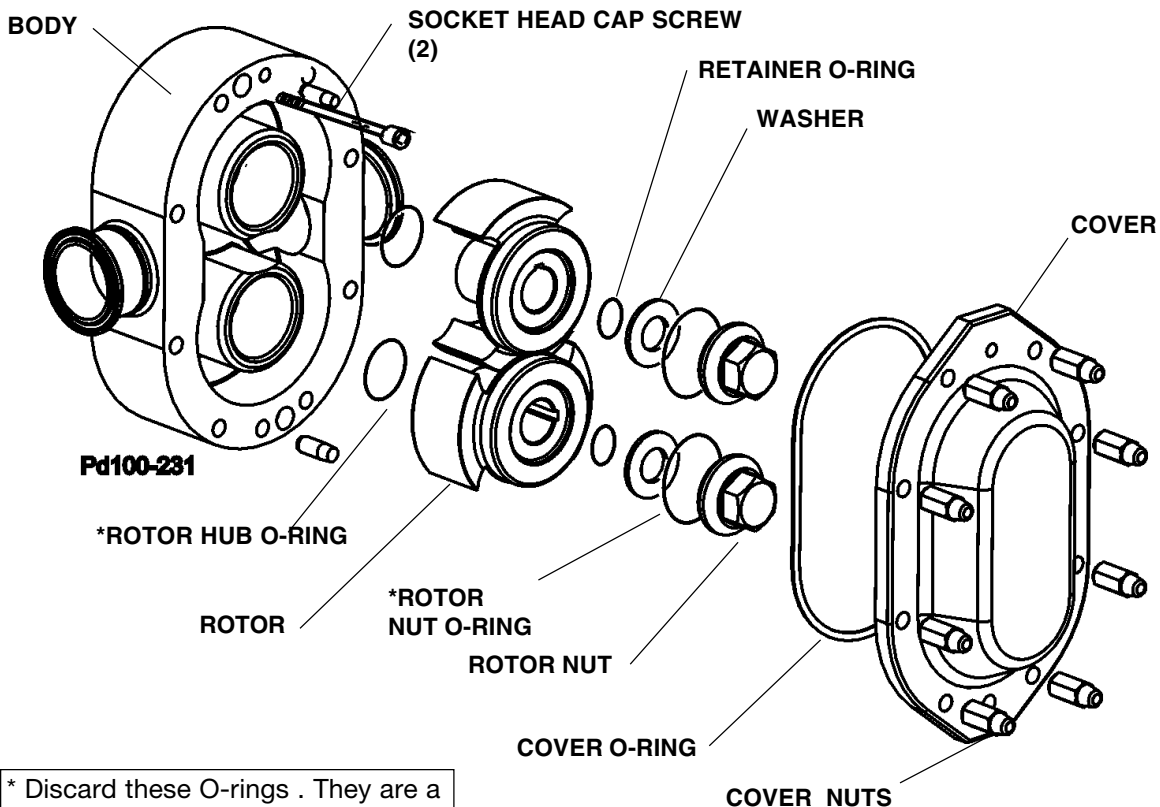

* Discard these O-rings . They are a "one time" use only.

DISASSEMBLY PROCEDURES

REMOVE SHAFTS, BEARINGS AND GEARS - ALL MODELS

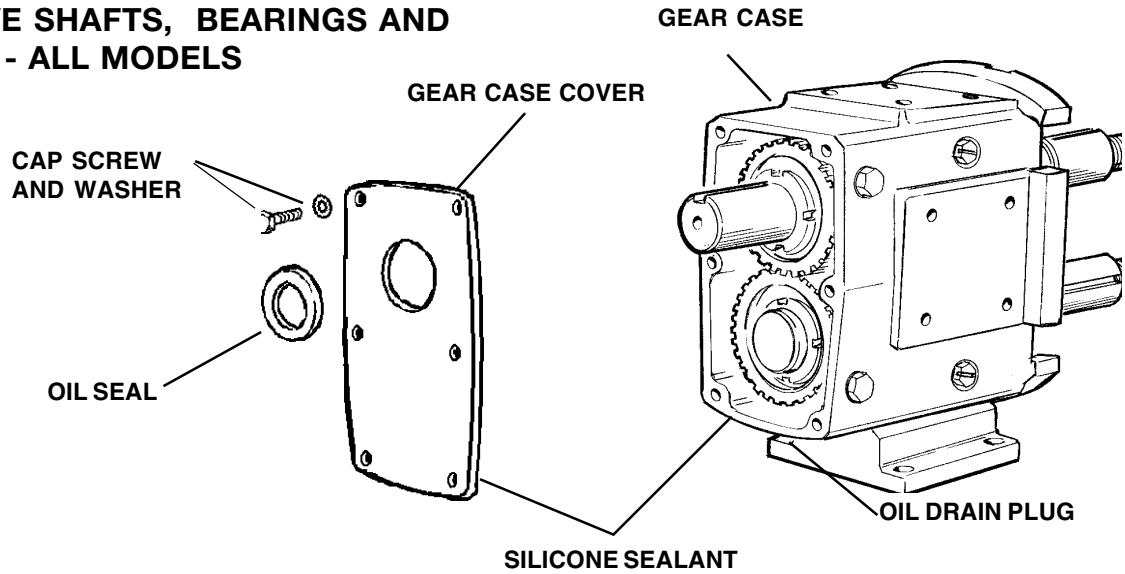

1. Remove oil drain plug and drain oil.
2. Remove cap screws from gear case cover.
3. Pull cover off shaft extension. If cover sticks, use soft hammer to loosen it.
4. Scrape silicone sealant from gear case and cover.
5. Remove oil seal from cover with an arbor press and discard.

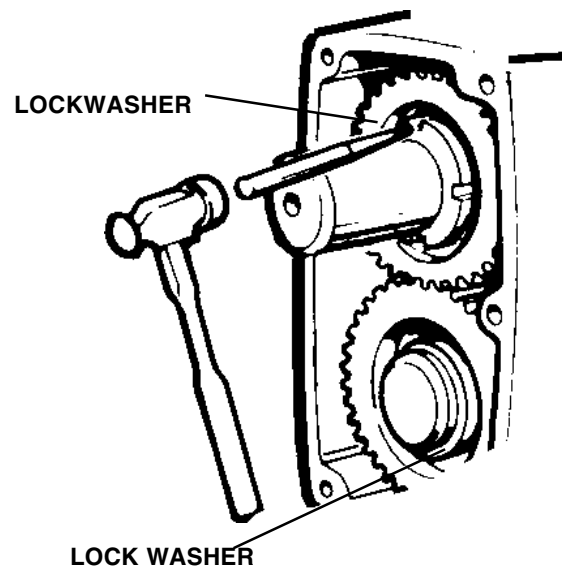

6. Straighten locking tab of lock washers.

DISASSEMBLY PROCEDURES

SHAFT REMOVAL

7. Prevent shafts from turning by wedging a wooden block between the gears.

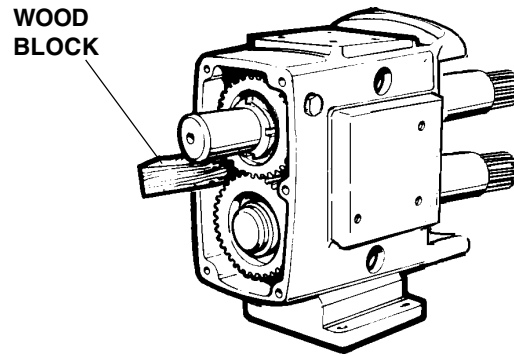

8. Use spanner wrench or drift to remove gear lock nuts. Gears will be removed later. See step 10 below.

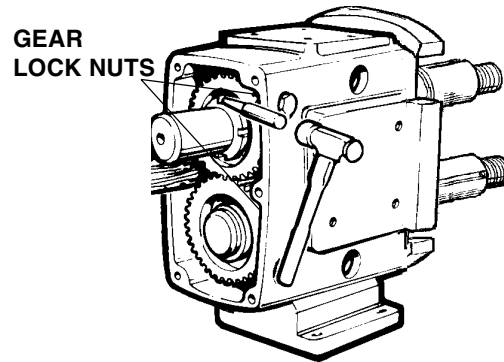

NOTE: Protect liquid end of shafts by wrapping them with tape.

9. Remove front bearing retainer bolts and pull off retainers. Scrape silicone sealant from retainer and case. (If retainer is stuck, leave it in place; it will press out when shaft is removed.)

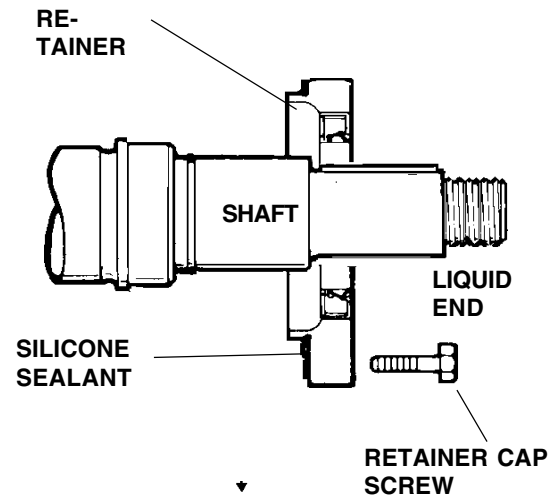

10. Place gear case on an arbor press with liquid end down. Protect shaft ends with wood or plastic block and press shafts out of gear case. Remove timing gears and spacers from drive end. (See Table 4 on Page 33 for hydraulic press tonnage required.)

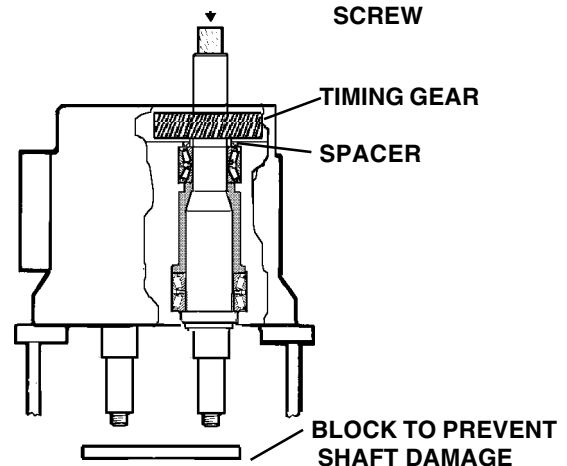

DISASSEMBLY PROCEDURES

11. Scrape silicone sealant; press out and discard grease seal from front bearing retainers.

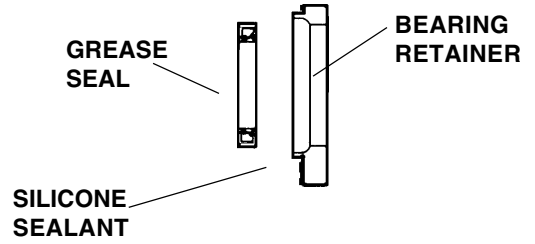

12. Remove shims. If they are to be re-used, identify them with the shaft on which they were used.

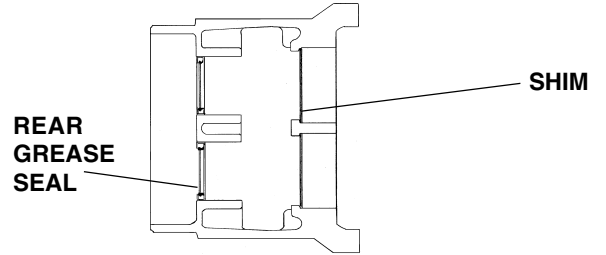

13. Press out and discard both rear grease seals in gear case.

14. Use hydraulic press and V-blocks to remove bearings and spacer. (See Table 4 on Page 33.)

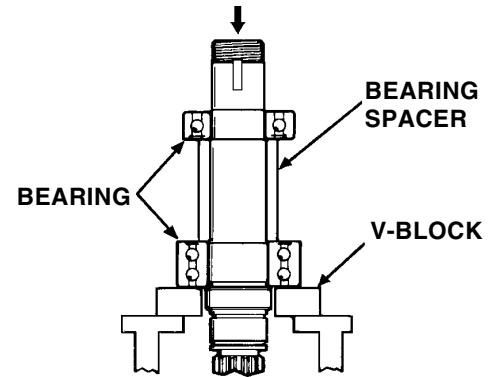

SECTION IX ASSEMBLY PROCEDURES

NEED TO REPLACE ROTOR KEY ASSEMBLY?

1. CLEAN ANY RESIDUAL ADHESIVE FROM SHAFT.
2. APPLY LOCQUIC® PRIMER T-747 TO KEYWAY PER PACKAGE INSTRUCTIONS.
3. APPLY LOCTITE® THREADLOCKER 272 TO KEY WAY.
4. INSERT KEY, CLAMP IN PLACE AND ALLOW 24 HOURS CURE TIME FOR THE THREADLOCKER.

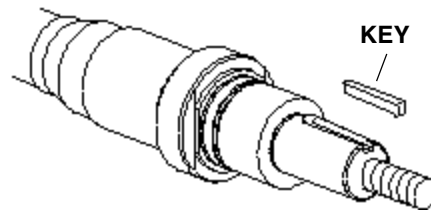

Shaft Assembly

1. Front Bearing Assembly

a. Coat front bearing area of shaft with Micro-Plate #555 grease. Place upright in hydraulic press with spline end down.

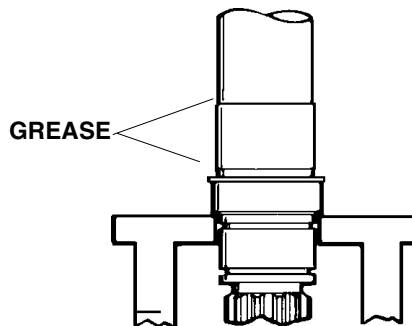

b. Unwrap front bearing assembly. Do not interchange parts of one bearing assembly with another. These parts are precisely matched in manufacture and must be installed as a matched assembly.

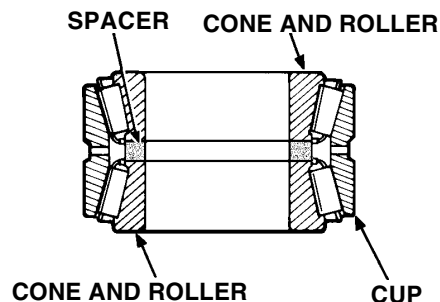

c. Lift cone and roller assembly out of bearing stack and place on shaft with radius down as shown. Press onto shaft until seated against shaft shoulder.

(See Table 4 on Page 33.)

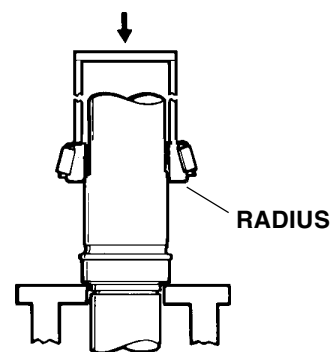

d. Place spacer over shaft onto bearing cone.

e. Place bearing cup over cone and roller assembly, keeping the cup oriented with proper roller assembly.

f. Coat remaining bearing cone and roller inside diameter with Micro-Plate grease and slip them over shaft with roller radius up. Press onto shaft and into cup to complete assembly of front bearing on shaft.

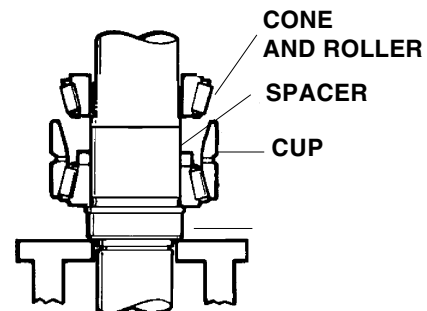

ASSEMBLY PROCEDURES

2. Rear Bearing Assembly

a. Unwrap rear bearing assembly. Do not interchange parts of one bearing assembly with another. These parts are precisely matched in manufacture and must be installed as a matched assembly.

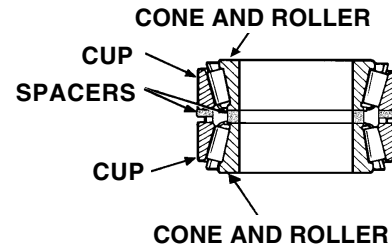

b. Place shaft upright in an arbor press with gear end up. Install bearing spacer on all model shafts.

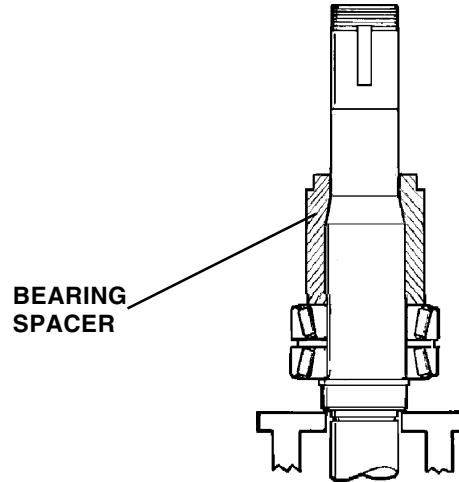

c. Coat shaft bearing area with Micro Plate grease. Press bearing cone and roller assembly (with radius down) onto shaft. (For hydraulic press tonnage required, see Table 4 on Page 33)

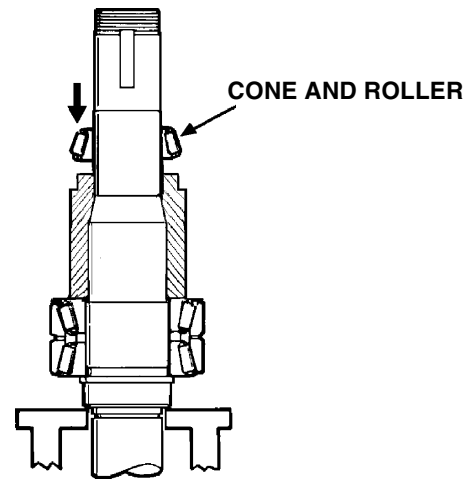

d. Apply Micro Plate grease again. Slip bearing cup over roller assembly. Install both inner and outer spacers. Place remaining cup onto outer spacer and press on the remaining cone and roller assembly. (See Table 4 on Page 33.)

Be sure outer spacer is concentric on shaft.

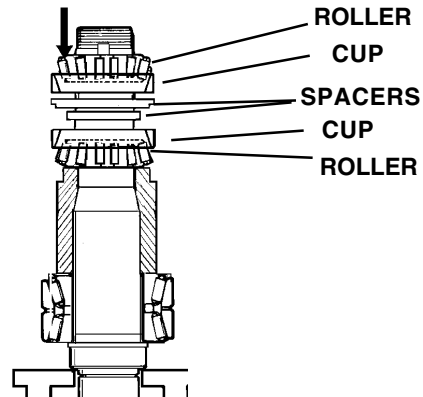

ASSEMBLY PROCEDURES

Gear Case Assembly

1. Shaft Installation

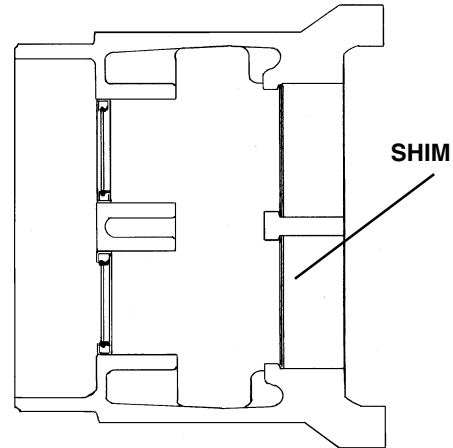

Shims - ALL MODELS

a. To determine the shim thickness required for the front bearing, measure dimension "B" in the gear case and dimension "C" on the shaft to three decimal places (1.000, for example) . Also measure the thickness of the body (D), minus the depth (E). Add the difference to dimension B.

Using these values to calculate the shim thickness as follows:

Dimension "B" + "difference" minus dimension "C" = required shim thickness.

b. Use standard shim packs to equal the required shim thickness. Place against shoulder in front bearing bore. (Also see Page 33.)

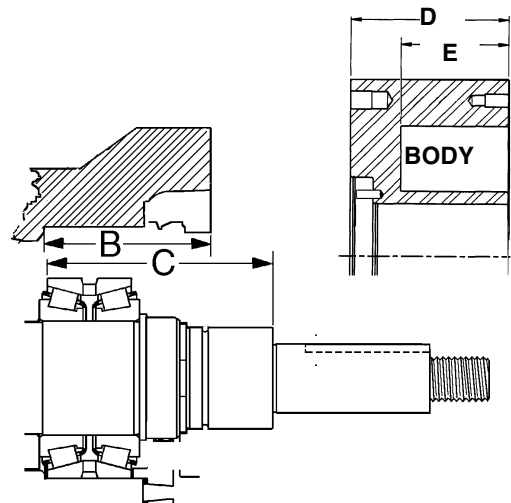

INSTALL SHAFTS

- Install shaft assemblies in gear case with spline end up and the drive shaft in proper location to give top or bottom drive as required.
- Press shafts into gear case until seated against shim pack.

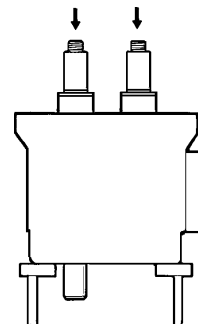

ASSEMBLY PROCEDURES

e. Secure shaft assemblies in gear case with bearing retainers. No silicone sealant at this time.

NOTE: Retainer must seat firmly against bearing and leave .010"-.050" clearance with gear case. Use shims between bearing and retainer if required.

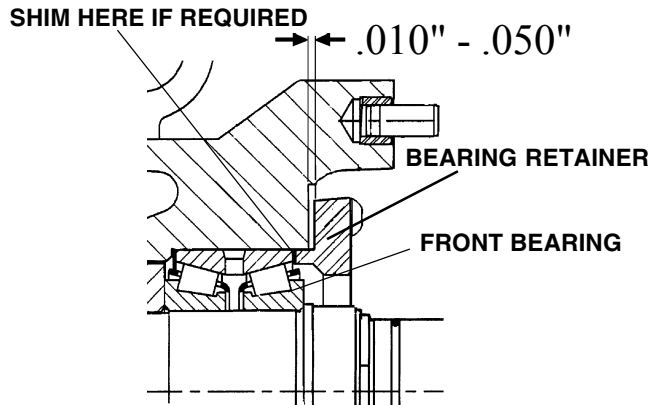

f. Check back face clearance. See Table 4 on Page 35 and BACK FACE CLEARANCE, page 34.

g. Remove bearing retainers.

h. Grease front and rear bearing through grease fittings until grease is visible around ball assemblies.

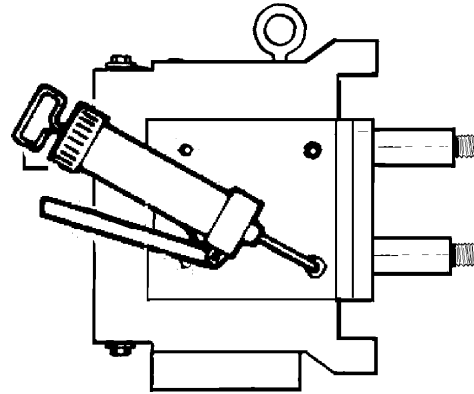

i. Install grease seals in bearing retainers (lip in) and coat seal lips with Micro-Plate #555 grease. Coat retainer flanges with silicone sealant.

j. Install bearing retainers.

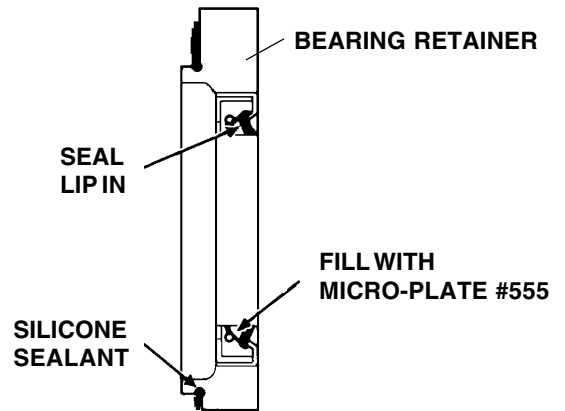

2. Rear Seal Assembly

a. Install gear spacers.

b. Coat lip of seals with Micro-Plate grease #555.

c. Press in rear seals with lip facing out.

NOTE: Place plastic bag over shaft end to prevent cutting seal when installing.

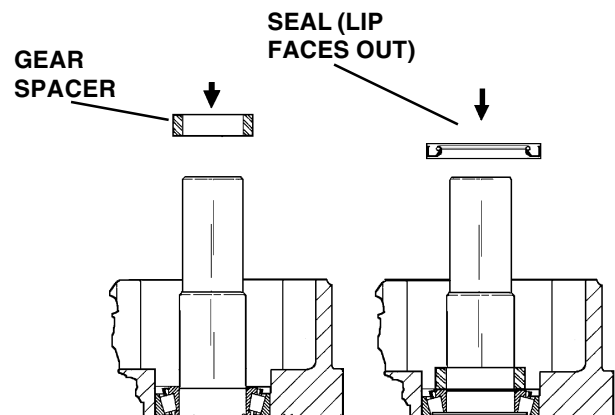

ASSEMBLY PROCEDURES

TIMING GEAR AND GEAR COVER ASSEMBLY- ALL MODELS

1. Place keys into shaft key slots. Slide gear with single punch mark onto drive shaft. Slide gear with two punch marks onto the short shaft with punch marks straddling single mark of drive gear.

NOTE: Rotors must be at right angles. Shim a gear out to obtain proper timing if necessary.

2. Secure shafts from turning with a wood block wedged between gears or rotors.

3. Apply Micro-Plate grease to threaded area on shafts and face of lock nuts.

4. Slip on lock washers and lock nuts. Tighten lock nuts with a spanner wrench or drift. Bend locking tab to secure. See Table 2 on Page 35 for proper torque limit.

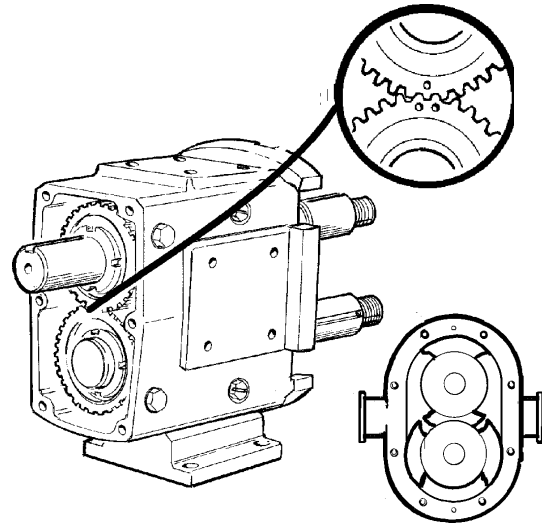

5. Press new oil seal into gear cover with lip facing in.

6. Place silicone sealant on back of gear cover and mount cover assembly onto gear case. (*Tape shaft end to prevent cutting seal on keyway.*) Secure with cap screws.

7. Install oil drain plug. Fill gear case with Micro-Plate #140 oil to proper level. (See OPERATION on page 15)

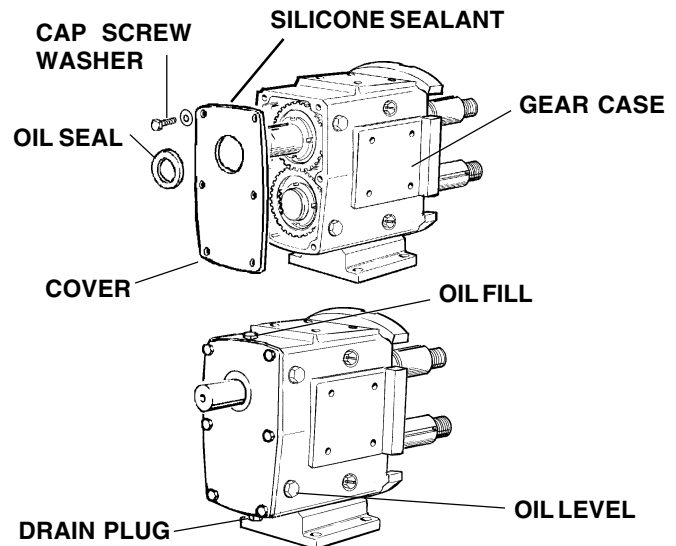
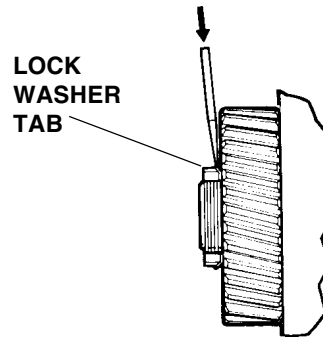
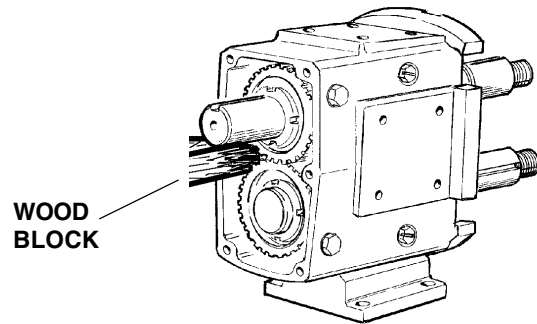

ASSEMBLY PROCEDURES

PROPER CLEARANCES

1. All Waukesha pumps are designed with close running clearances and the back face clearance is established with shims during assembly. The shaft is positioned with shims behind the front bearing and locked into the bearing gear case. The rotors lock against the shaft shoulder and the resultant clearance between body back face and rotor wing is the back face clearance. (See Table 1, Page 33, for STANDARD CLEARANCES)

2. To check back face clearance, mount body onto bearing gear case and secure with retaining screws. Assemble rotors and secure with rotor nut assemblies. Measure clearance between body back face and rotor wing with feeler gauges. This can be done by inserting the feeler gauge in between the rotor wings and bending the gauge into position behind the wing or inserting the gauge into a side port and behind the rotor wing. Check readings against recommended STANDARD back face clearance in Table 1, Page 33. Make note of any corrections required and follow examples to determine exact shim adjustment to make and avoid unnecessary disassembly and reassembly.

3. To make shim adjustments it is necessary to disassemble rotors and body and remove shafts. (See Section VIII, FLUID HEAD DISASSEMBLY on page 20.) Make required shim adjustment and reassemble. Recheck back face clearances. Be sure both rotors have the same clearance to avoid crossover interference.

Object: Backface dimension (A) is the difference between the shaft shoulder to the gearcase shoulder (F) and the body thickness (G). (Measure rotor depth (E) and subtract from total body thickness (D) to determine (G).

A= BACK FACE CLEARANCE
 B= ROTOR TO BODY CLEARANCE
 C= FRONT FACE CLEARANCE

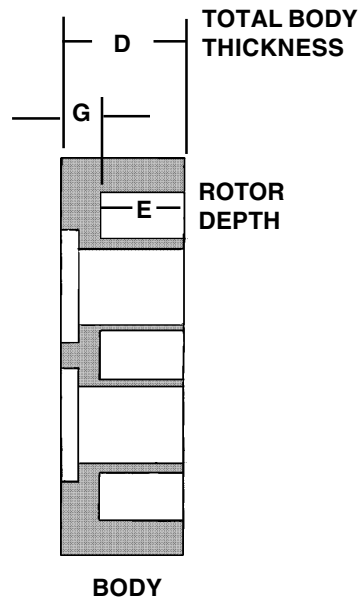
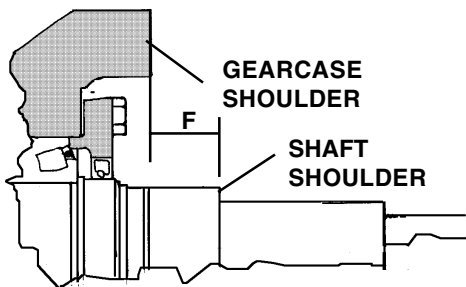
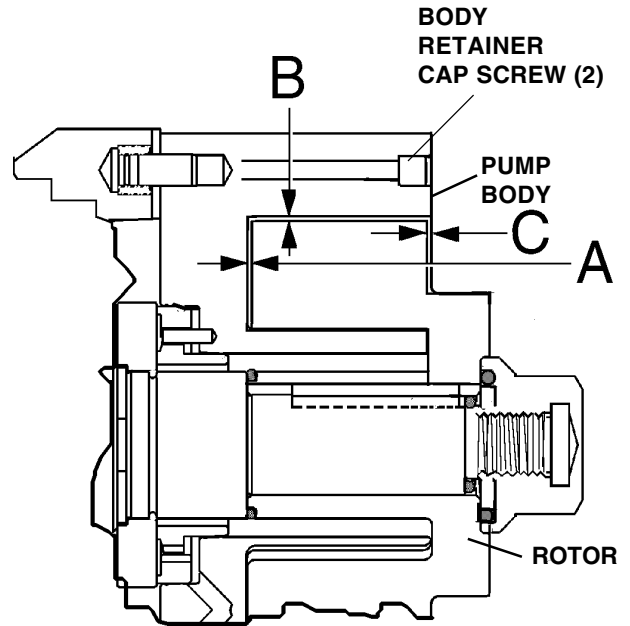

NOTE: Back face clearance for, both rotors must be the same to avoid crossover interference with rotor hubs.

UNIVERSAL II SEAL COMPONENTS

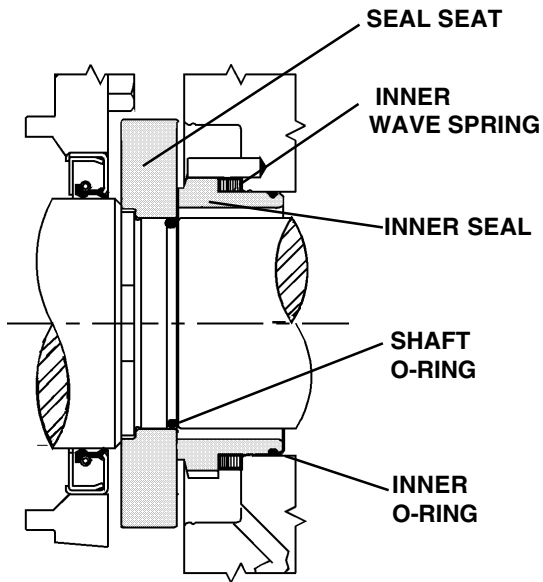

SINGLE MECHANICAL SEAL

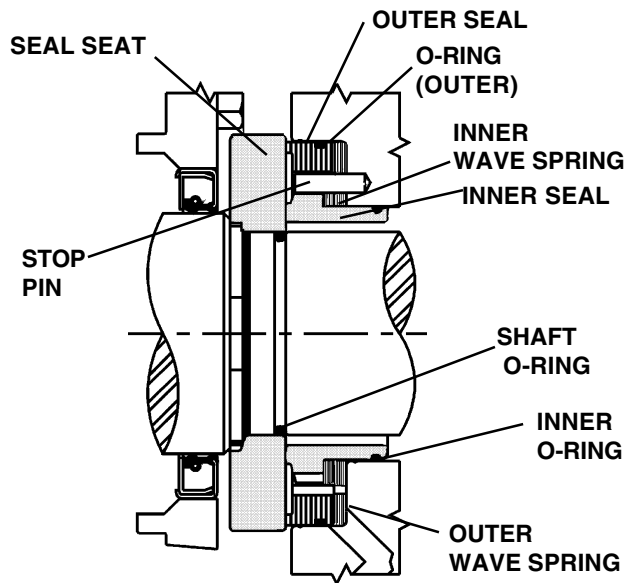

DOUBLE MECHANICAL SEAL

ASSEMBLY PROCEDURES

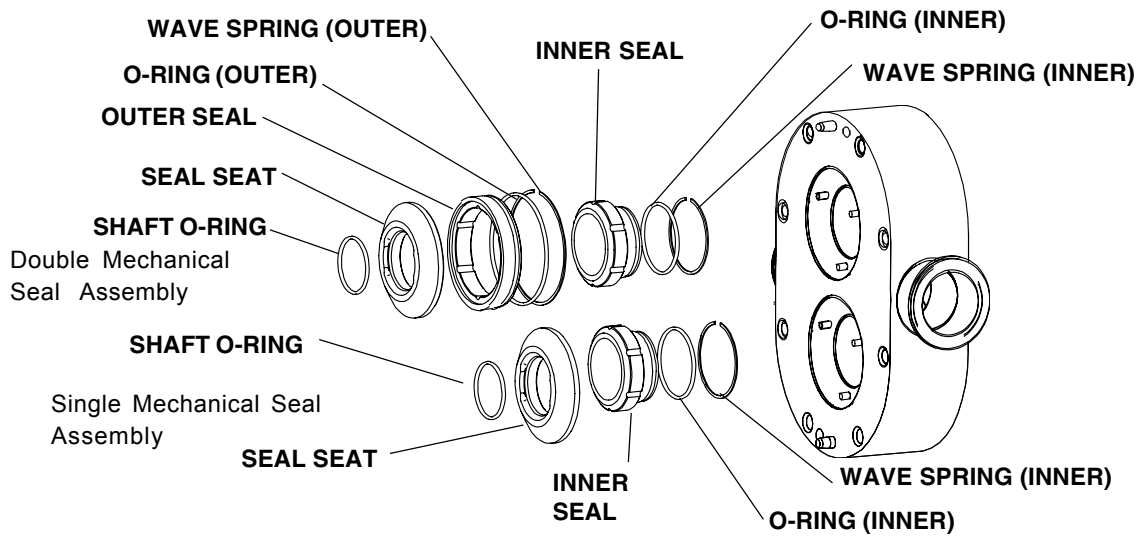

SINGLE AND DOUBLE MECHANICAL SEAL ASSEMBLIES

SHAFTS:

1. Place O-ring on shaft.
2. Install seal seat onto shaft. Align drive flats on seat with the drive flats on the shaft. Push seat squarely against shaft shoulder.

BODY:

3. Install wave spring on the inner seal and O-ring onto outer groove of inner seat.

4. Place inner seal into back of pump body. Be sure to align notches in inner seal with stop pins in the body. Push evenly and firmly in place,

5. If a double seal is required, install a wave spring over inner seal assembly and an outer seal O-ring onto outer seal groove. Place outer seal into pump body over inner seal. Be sure to align notches in outer seal with stop pins in body. Perform this procedure on both shafts.

ASSEMBLY PROCEDURES

INSTALL BODY

1. Install the body to pump gear case assembly. Use care to avoid damaging seals as the body is drawn over the shafts. Use two (2) socket head cap screws to secure the body to the gear case.

INSTALL ROTORS

2. Install new rotor hub O-rings onto groove in rotors. Install rotors onto shafts.
Lubricate all O-rings with a lubrication compound that is compatible with O-ring material and process fluid/s.

INSTALL ROTOR NUT ASSEMBLIES

3. Install Belleville washer into rotor nut with cone of washer "pointing" toward the nut. Place retainer O-ring into rotor nut to retain washer.

4. Install new rotor nut O-ring onto rotor nut. Screw rotor nuts onto shafts (clockwise) and tighten to required torque.

Warning: If rotor nuts are not tightened to the proper torque, the nuts could loosen during operation causing severe damage to the pump. Always use a torque wrench!

INSTALL COVER

5. Install cleaned cover O-ring into groove in cover and install cover onto pump. Tighten cover securely using cover nuts.

NOTE: Apply a food grade anti-seize compound to shaft and body studs prior to assembly of rotors and cover.

IMPORTANT! If a double seal arrangement is used, the seals must be provided with a clean, compatible barrier fluid. Make certain that flush ports in pump body are clean and clear.

See Table on page 33 for wrench size and torque values)

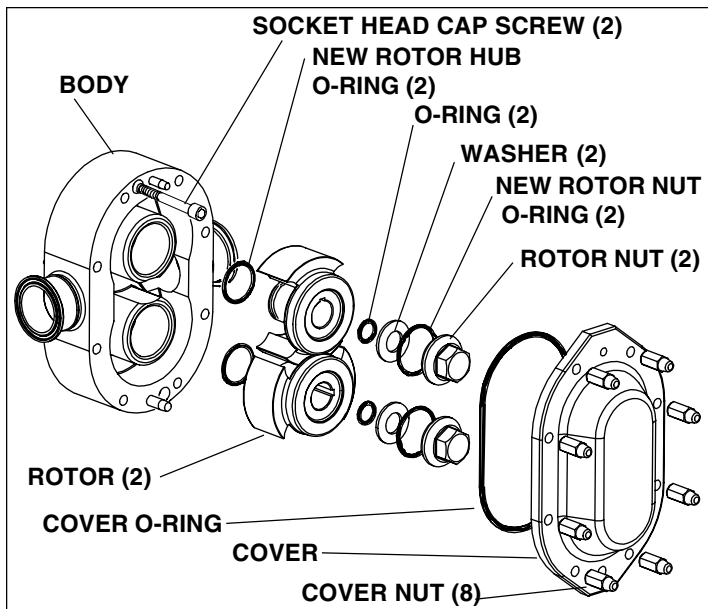

SECTION X

REFERENCE TABLES AND REPAIR PARTS LIST

TABLE 1. STANDARD ROTOR CLEARANCES*- INCHES

MODEL	A BACK FACE	B ROTOR TO BODY	C FRONT FACE
006U2 015U2 018U2	0.002"	0.002"	0.005"
030U2	0.002"	0.002"	0.005"
045U2 060U2 130U2	0.004"	0.005"	0.008"
180U2 220U2	0.005"	0.006"	0.008"
320U2	0.005"	0.010"	0.011"

**For non-standard rotor clearance, contact Application Engineering at Waukesha Cherry-Burrell*

TABLE 2. TORQUE VALUES-FT-LBS

MODEL	LOCK NUTS	
	GEAR	ROTOR
006U2	75	50
015U2	75	50
018U2	75	50
030U2	100	120
045U2	140	250
060U2	140	250
130U2	140	250
180U2	230	325
220U2	230	325
320U2	320	375

TABLE 3. SUGGESTED SHIMS - INCHES

SERIES MODEL	STANDARD SHAFT	REPLACEMENT SHAFT
006U2 015U2 018U2	0.113"	0.110"
030U2	0.105"	0.102"
045U2 060U2 130U2	0.093"	0.088"
180U2 220U2	0.115"	0.110"
320U2	0.125"	0.120"

UNIVERSAL II SERIES WRENCH SIZES - INCHES

MODEL	ROTOR NUT	EARLY COVER NUT	BODY RETAINER BOLT	8/98 COVER NUT
006U2 015U2 018U2	15/16"	7/16"	3/16"	5/8"
030U2	1-1/4"	1/2"	3/16"	5/8"
045U2 060U2 130U2	1-5/8"	9/16"	1/4"	1"
180U2 220U2	2-1/4"	5/8"	5/16"	1"
320U2	2-3/8"	1"	5/16"	1"

NOTE: Applications over 200 PSI when used with the 8/98 cover nuts will require the 8/98 studs.

TABLE 4. ARBOR OR HYDRAULIC PRESS REQ'D - TONS

SERIES MODEL	SHAFT		FRONT BEARING		REAR BEARING SHAFT	
	IN	OUT	ON	OFF	ON	OFF
006U2 015U2 018U2	0.25	0.5	0.5	1	0.5	1
030U2	0.25	1	0.5	1	0.5	1
045U2 060U2 130U2	0.5	1	2	5	3	5
180U2 220U2	0.5	1	5	15	5	15
320U2	0.5	1	5	20	5	20

8-28-98

O-RING INDEX

Model	Material	Inner Seal	Outer Seal	Seal Seat	Dynamic	Rotor Hub	Rotor Nut	Retainer	Cover
006U2	Buna N	N70028	N70035	N70024	N70125	N70121	N70126	N70112	N70249
015U2	EPDM	E70028	E70035	E70024	E70125	E70121	E70126	E70112	E70249
018U2	Fluoroelastomer	V70028	V70035	V70024	V70125	V70121	V70126	V70112	V70249
030U2	Buna N	N70031	N70041	N70029	N70224	N70127	N70130	N70115	N70259
	EPDM	E70031	E70041	E70029	E70224	E70127	E70130	E70115	E70259
	Fluoroelastomer	V70031	V70041	V70029	V70224	V70127	V70130	V70115	V70259
045U2	Buna N	N70035	N70043	N70133	N70227	N70224	N70227	N70119	N70373
060U2	EPDM	E70035	E70043	E70133	E70227	E70224	E70227	E70119	E70373
130U2	Fluoroelastomer	V70035	V70043	V70133	V70227	V70224	V70227	V70119	V70373
180U2	Buna N	N70041	N70046	N70145	N70233	N70230	N70235	N70122	N70381
220U2	EPDM	E70041	E70046	E70145	E70233	E70230	E70235	E70122	E70381
	Fluoroelastomer	V70041	V70046	V70145	V70233	V70230	V70235	V70122	V70381
320U2	Buna N	N70154	N70160	N70145	-	N70232	N70237	N70125	N70383
	EPDM	E70154	E70160	E70145	-	E70232	E70237	E70125	E70383
	Fluoroelastomer	V70154	V70160	V70145	-	V70232	V70237	V70125	V70383

SECTION XI PARTS LISTS

Illustrated Parts Identification for Universal II Pumps STANDARD and STAINLESS STEEL

Model	Page
006U2	36-37
015U2	38-39
018U2	40-41
030U2	42-43
045U2	44-45
060U2	46-47
130U2	48-49
180U2	50-51
220U2	52-53
320U2	54-55
SINGLE MECHANICAL SEALS	56,59
DOUBLE MECHANICAL SEALS	57-59
LABEL PLACEMENT	61
PARTS ORDER INFORMATION.....	62

OPTIONAL PUMP FEATURES

Waukesha Universal II pumps are available with optional features which affect the material/design (and part number) of certain parts. When ordering these parts, specify your pump serial number and part description to ensure getting the correct part. When converting from one design to another, contact Waukesha Customer Service with pump serial number.

OPTIONAL FEATURE	DESCRIPTION	PARTS AFFECTED
<p>Stainless Steel Gearcase</p> <p>Seal Flush</p>	<p>when mounted in side mount position Gearcase, fasteners, and all associated parts made from stainless steel (no painted parts)</p> <p>Double shaft seal requires flush drilling/tapping in body</p>	<p>Gearcase, gearcase cover fasteners, mounting foot, nameplate, oil seals, oil plug</p> <p>Body</p>
<p>Port Connections</p> <p>Rotor</p> <p>Shaft Seal Components</p>	<p>Available port connections include; S-clamp, bevel seat, I-line, Q-line, DIN, flange</p> <p>Available rotor option include: material; std. alloy 88, 316 SS wings; std. 2 single clearance; standard, hot, front face, extra</p> <p>Single Mechanical Double Mechanical</p>	<p>Body</p> <p>Rotor</p> <p>For materials available, See Pages 56-59 and Page 34</p>

UNIVERSAL II SERIES Model 006U2

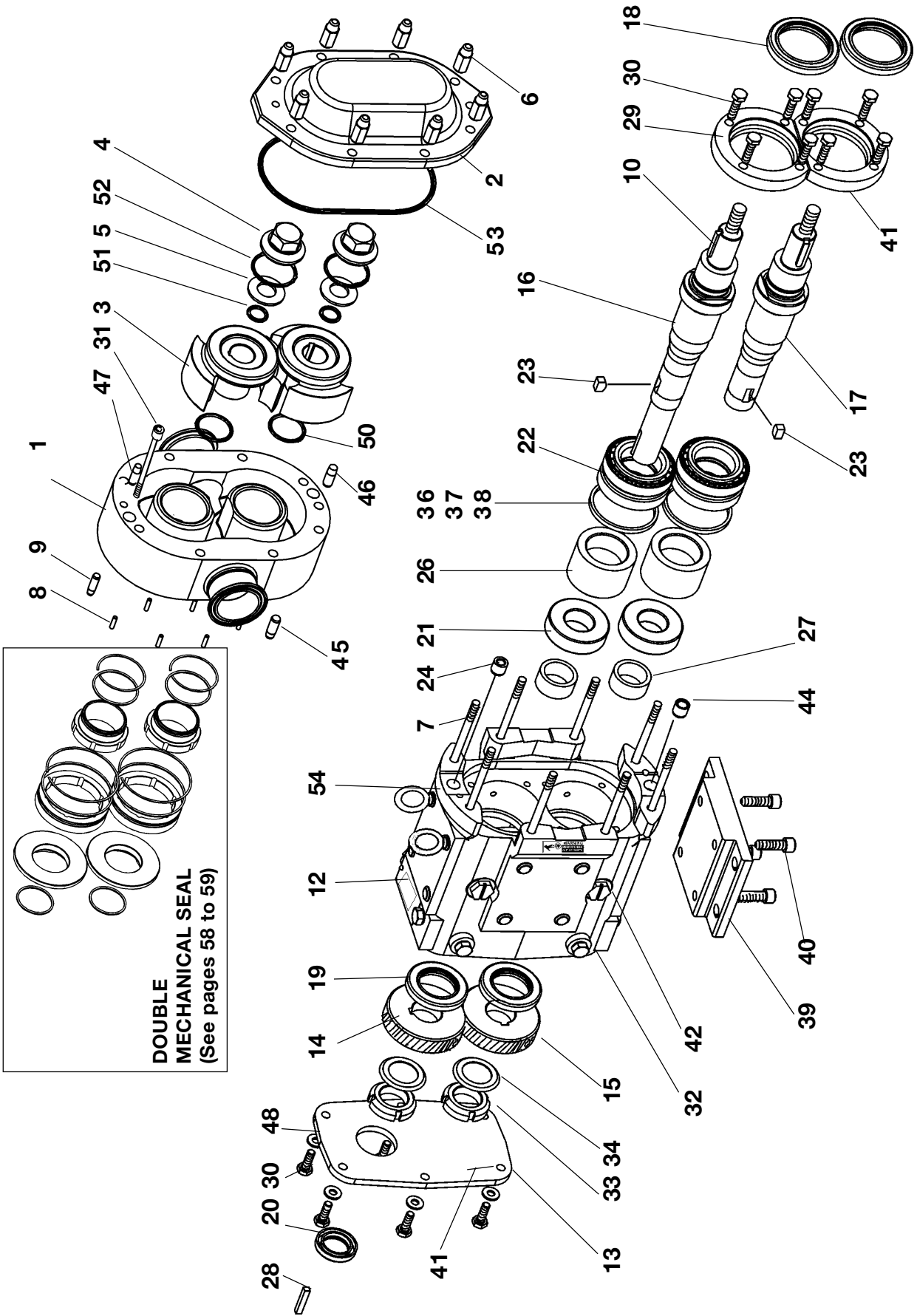

ITEM	DESCRIPTION	PART NUMBER	QTY	ITEM	DESCRIPTION	PART NUMBER	QTY
1	Body	(See Special Note)	1	36	Shim, Front Bearing 0.002"	101723	4
2	Cover, Standard Stainless	101842	1	37	Shim, Front Bearing 0.010"	101726	2
3	Rotor	(See Special Note)	2	38	Shim, Front Bearing 0.050"	101727	4
4	Rotor Nut	101804	2	39	Mounting Foot, Gear Case	020 110 000	1
5	Washer, Belleville	101691	2		Mounting Foot, Gear Case, SS	102284	1
6	Nut, Cover	108369	8	40	Cap Screw, Soc. Hd. Zinc Plated	30-343	4
7	Stud, Body	AD0 011 000	8		Cap Screw, Soc. Hd. SS 18-8	30-525	4
8	Stop Pin 303 SS	101718	6	41	Silicone Sealant, RTV	000 142 300	AR
9	Dowel Pin, Upper, Case	AD0 040 R00	1	42	Cleanout Plug 1-1/16-12	35824	2
10	Key, Rotor	101817	2		Cleanout Plug 1-1/16-12 SS	102298	2
12	Gear Case	102276	1		O-Ring, Buna	N70114	2
	Gear Case, Stainless Steel	101831	1	44	Bushing, Dowel, Lower	AD0 116 100	1
13	Gear Case Cover	020 006 000	1	45	Dowel Pin, Lower	AD0 040 R10	1
	Gear Case Cover, SS	102280	1	46	Dowel Pin, Cover, Lower	AD0 040 100	1
14	Gear, RH	015 007 001	1	47	Dowel Pin, Cover, Upper	AD0 040 000	1
15	Gear, LH	015 007 002	1	48	Washer, 3/8 ZP	43-108	6
16	Drive, Shaft	101730	1	*	Name Plate	001 061 002	1
17	Short, Shaft	101731	1	*	RHDS, #2 x 1/8" 18 8 S.S.	AD0 062 000	4
18	Seal, Front Grease	101716	2	*	Grease Fitting	BD0 092 000	4
	Seal, Front Grease (Stainless)	102288	2	*	Plastic Cap, Grease Fitting	BD0 093 000	4
19	Seal, Oil	000 030 017	2	*	Caution Label	33-62	2
20	Seal, Input	000 030 016	1	50	O-Ring, Rotor Hub, Buna N	N70121	2
	Seal, Input (Stainless)	102292	1		O-Ring, Rotor Hub, EPDM	E70121	2
21	Bearing, Rear	015 035 000	2		O-Ring, Rotor Hub, Fluoroelastomer	V70121	2
22	Bearing, Front	101714	2	51	O-Ring, Retainer Buna N	N70112	2
23	Key, Gear	015 037 000	2		O-Ring, Retainer EPDM	E70112	2
24	Dowel Bushing, Upper, Case	AD0 116 000	1		O-Ring, Retainer Fluoroelastomer	V70112	2
26	Spacer, Bearing	101814	2	52	O-Ring, Rotor Nut Buna N	N70126	2
27	Spacer, Gear	015 055 000	2		O-Ring, Rotor Nut EPDM	E70126	2
28	Key, Motor	000 037 001	1		O-Ring, Rotor Nut Fluoroelastomer	V70126	1
29	Bearing Retainer, Front	101810	2	53	O-Ring, Cover Buna N	N70249	1
30	Cap Screw, Hex Hd. Zinc Plated	30-287	14		O-Ring, Cover EPDM	E70249	1
	Cap Screw, Hex Hd. SS	30-58	14		O-Ring, Cover Fluoroelastomer	V70249	1
31	Cap Screw, Soc. Hd., Body 18-8	30-523	2	54	Plug, Plastic 5/16 "	000 121 003	8
32	Oil Plug, 5/16-24 x 3/8 18-8	004 046 002	6		BSHCS 5/16-18 x 1/2	30-524	8
	Oil Plug, 5/16-24 x 3/8 18-8	30-524	6				
	O-Ring, Buna N	N70109	6				
33	Lock Nut NO5	STD 236 005	2				
34	Lockwasher W05	STD 136 005	2				

* Not Shown
 AR= As Required
 (Omit Item 48 on
 Stainless cases)

Special Note on page 35
For Stainless Steel Gear Cases

UNIVERSAL II SERIES Model 006U2

UNIVERSAL II SERIES Model 015U2

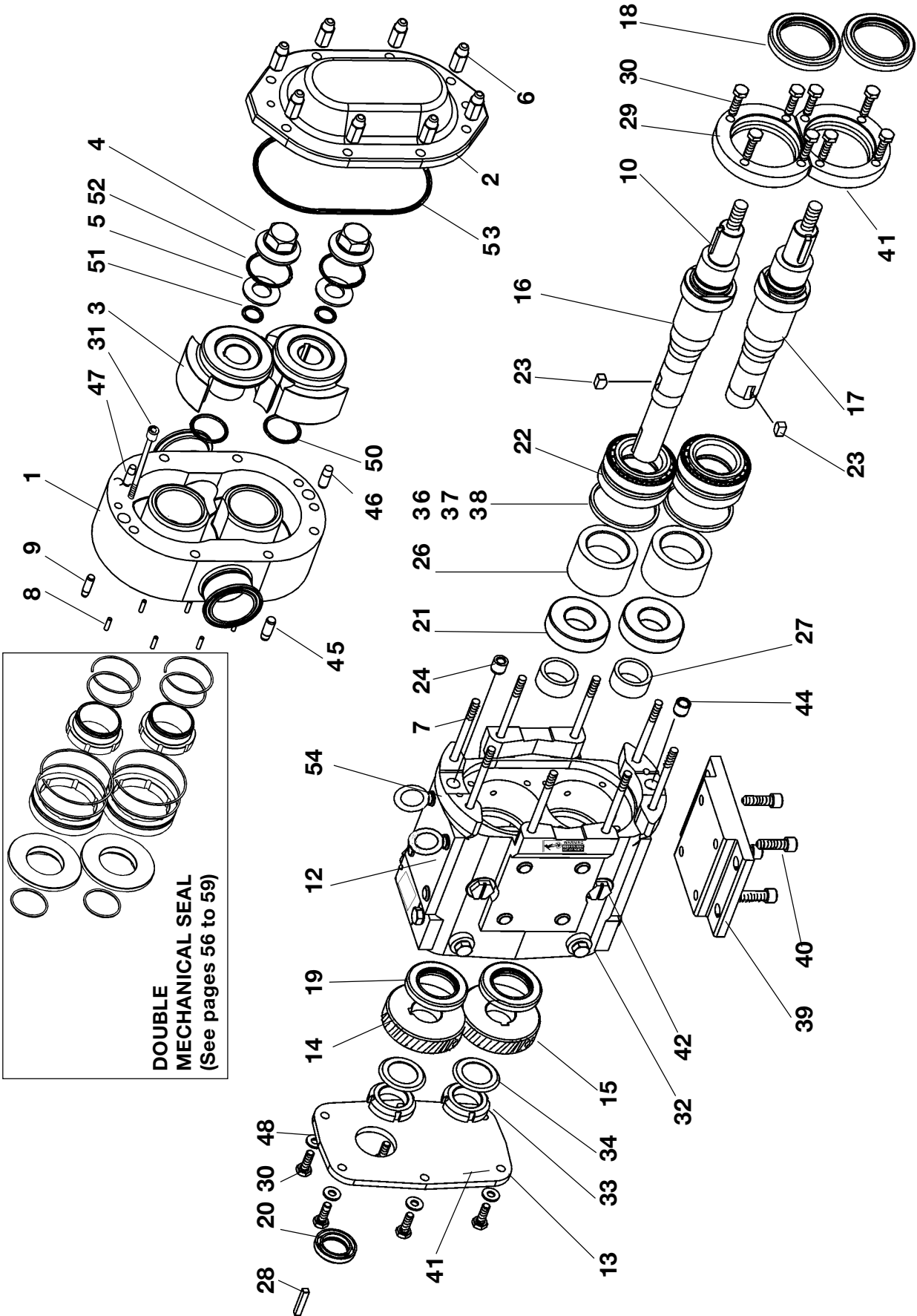

ITEM	DESCRIPTION	PART NUMBER	QTY
1	Body	(See Special Note)	1
2	Cover, Standard Stainless	101842	1
3	Rotor	(See Special Note)	2
4	Rotor Nut	101804	2
5	Washer, Belleville	101691	2
6	Nut, Cover	108369	8
7	Stud, Body	AD0 011 000	8
8	Stop Pin 303 SS	101718	6
9	Dowel Pin, Upper, Case	AD0 040 R00	1
10	Key, Rotor	101817	2
12	Gear Case	102276	1
	Gear Case, Stainless Steel	101831	1
13	Gear Case Cover	020 006 000	1
	Gear Case Cover, SS	102280	1
14	Gear, RH	015 007 001	1
15	Gear, LH	015 007 002	1
16	Drive, Shaft	101730	1
17	Short, Shaft	101731	1
18	Seal, Front Grease	101716	2
	Seal, Front Grease (Stainless)	102288	2
19	Seal, Oil	000 030 017	2
20	Seal, Input	000 030 016	1
	Seal, Input (Stainless)	102292	1
21	Bearing, Rear	015 035 000	2
22	Bearing, Front	101714	2
23	Key, Gear	015 037 000	2
24	Dowel Bushing, Upper, Case	AD0 116 000	1
26	Spacer, Bearing	101814	2
27	Spacer, Gear	015 055 000	2
28	Key, Motor	000 037 001	1
29	Bearing Retainer, Front	101810	2
30	Cap Screw, Hex Hd. Zinc Plated	30-287	14
	Cap Screw, Hex Hd. SS	30-58	14
31	Cap Screw, Soc. Hd., Body 18-8	30-523	2
32	Oil Plug, 5/16-24 x 3/8 18-8	004 046 002	6
	Oil Plug, 5/16-24 x 3/8 18-8	30-524	6
	O-Ring, Buna N	N70109	6
33	Lock Nut N05	STD 236 005	2
34	Lockwasher W05	STD 136 005	2

ITEM	DESCRIPTION	PART NUMBER	QTY
36	Shim, Front Bearing 0.002"	101723	4
37	Shim, Front Bearing 0.010"	101726	2
38	Shim, Front Bearing 0.050"	101727	4
39	Mounting Foot, Gear Case	020 110 000	1
	Mounting Foot, Gear Case, SS	102284	1
40	Cap Screw, Soc. Hd. Zinc Plated	30-343	4
	Cap Screw, Soc. Hd. SS 18-8	30-525	4
41	Silicone Sealant, RTV	000 142 300	AR
42	Cleanout Plug 1-1/16-12	35824	2
	Cleanout Plug 1-1/16-12 SS	102298	2
	O-Ring, Buna	N70114	2
44	Bushing, Dowel, Lower	AD0 116 100	1
45	Dowel Pin, Lower	AD0 040 R10	1
46	Dowel Pin, Cover, Lower	AD0 040 100	1
47	Dowel Pin, Cover, Upper	AD0 040 000	1
48	Washer, 3/8 ZP	43-108	6
*	Name Plate	001 061 002	1
*	RHDS, #2 x 1/8" 18 S.S.	AD0 062 000	4
*	Grease Fitting	BD0 092 000	4
*	Plastic Cap, Grease Fitting	BD0 093 000	4
*	Caution Label	33-62	2
50	O-Ring, Rotor Hub, Buna N	N70121	2
	O-Ring, Rotor Hub, EPDM	E70121	
	O-Ring, Rotor Hub, Fluoroelastomer	V70121	
51	O-Ring, Retainer Buna N	N70112	2
	O-Ring, Retainer EPDM	E70112	
	O-Ring, Retainer Fluoroelastomer	V70112	
52	O-Ring, Rotor Nut Buna N	N70126	2
	O-Ring, Rotor Nut EPDM	E70126	
	O-Ring, Rotor Nut Fluoroelastomer	V70126	
53	O-Ring, Cover Buna N	N70249	1
	O-Ring, Cover EPDM	E70249	
	O-Ring, Cover Fluoroelastomer	V70249	
54	Plug, Plastic 5/16"	000 121 003	8
	BSHCS 5/16-18 x 1/2	30-524	8

* Not Shown

AR= As Required
(Omit item 48 on
Stainless cases)

Special Note on page 35

For Stainless Steel Gear Cases

UNIVERSAL II SERIES Model 015U2

UNIVERSAL II SERIES Model 018U2

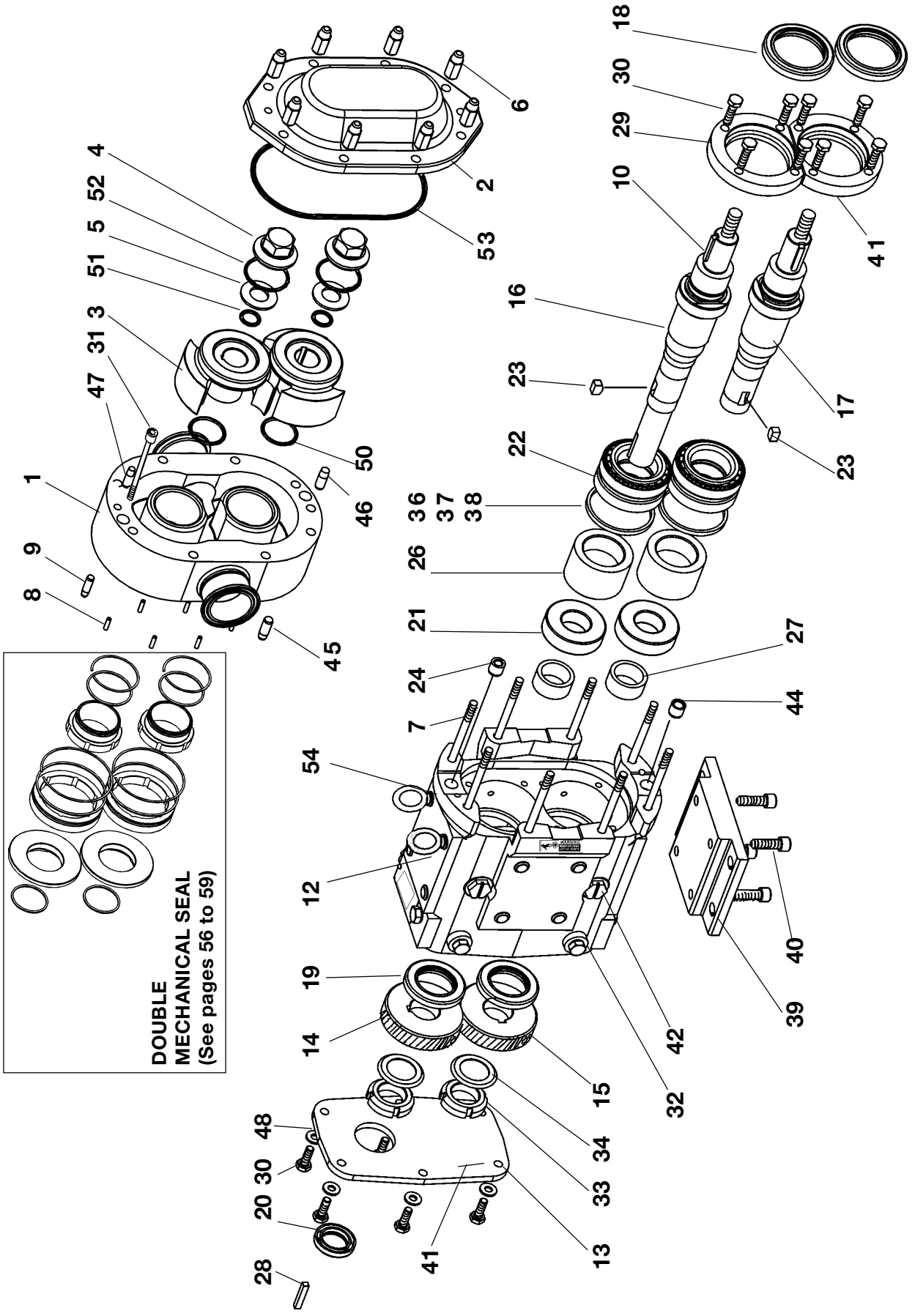

ITEM	DESCRIPTION	PART NUMBER	QTY
1	Body	(See Special Note)	1
2	Cover, Standard Stainless	101842	1
3	Rotor	(See Special Note)	2
4	Rotor Nut	101804	2
5	Washer, Belleville	101691	2
6	Nut, Cover	108369	8
7	Stud, Body	101721	8
8	Stop Pin 303 SS	101718	6
9	Dowel Pin, Upper, Case	AD0 040 R00	1
10	Key, Rotor	101819	2
12	Gear Case	102276	1
	Gear Case, Stainless Steel	101831	1
13	Gear Case Cover	020 006 000	1
	Gear Case Cover, SS	102280	1
14	Gear, RH	015 007 001	1
15	Gear, LH	015 007 002	1
16	Drive, Shaft	101742	1
17	Short, Shaft	101743	1
18	Seal, Front Grease	101716	2
	Seal, Front Grease (Stainless)	102288	2
19	Seal, Oil	000 030 017	2
20	Seal, Input	000 030 016	1
	Seal, Input (Stainless)	102292	1
21	Bearing, Rear	015 035 000	2
22	Bearing, Front	101714	2
23	Key, Gear	015 037 000	2
24	Dowel Bushing, Upper, Case	AD0 116 000	1
26	Spacer, Bearing	101814	2
27	Spacer, Gear	015 055 000	2
28	Key, Motor	000 037 001	1
29	Bearing Retainer, Front	101810	2
30	Cap Screw, Hex Hd. Zinc Plated	30-287	14
	Cap Screw, Hex Hd. SS	30-58	14
31	Cap Screw, Soc. Hd., Body 18-8	30-211	2
32	Oil Plug, 5/16-24 x 3/8 18-8	004 046 002	6
	Oil Plug, 5/16-24 x 3/8 18-8	30-524	6
	O-Ring, Buna N	N70109	6
33	Lock Nut NO5	STD 236 005	2
34	Lockwasher W05	STD 136 005	2

ITEM	DESCRIPTION	PART NUMBER	QTY
36	Shim, Front Bearing 0.002"	101723	4
37	Shim, Front Bearing 0.010"	101726	2
38	Shim, Front Bearing 0.050"	101727	4
39	Mounting Foot, Gear Case	020 110 000	1
	Mounting Foot, Gear Case, SS	102284	1
40	Cap Screw, Soc. Hd. Zinc Plated	30-343	4
	Cap Screw, Soc. Hd. SS 18-8	30-525	4
41	Silicone Sealant, RTV	000 142 300	AR
42	Cleanout Plug 1-1/16-12	35824	2
	Cleanout Plug 1-1/16-12 SS	102298	2
	O-Ring, Buna	N70114	2
44	Bushing, Dowel, Lower	AD0 116 100	1
45	Dowel Pin, Lower	AD0 040 R10	1
46	Dowel Pin, Cover, Lower	AD0 040 100	1
47	Dowel Pin, Cover, Upper	AD0 040 000	1
48	Washer, 3/8 ZP	43-108	6
*	Name Plate	001 061 002	1
*	RHDS, #2 x 1/8" 18 8 S.S.	AD0 062 000	4
*	Grease Fitting	BD0 092 000	4
*	Plastic Cap, Grease Fitting	BD0 093 000	4
*	Caution Label	33-62	2
50	O-Ring, Rotor Hub, Buna N	N70121	2
	O-Ring, Rotor Hub, EPDM	E70121	
	O-Ring, Rotor Hub, Fluoroelastomer	V70121	
51	O-Ring, Retainer Buna N	N70112	2
	O-Ring, Retainer EPDM	E70112	
	O-Ring, Retainer Fluoroelastomer	V70112	
52	O-Ring, Rotor Nut Buna N	N70126	2
	O-Ring, Rotor Nut EPDM	E70126	
	O-Ring, Rotor Nut Fluoroelastomer	V70126	
53	O-Ring, Cover Buna N	N70249	1
	O-Ring, Cover EPDM	E70249	
	O-Ring, Cover Fluoroelastomer	V70249	
54	Plug, Plastic 5/16 "	000 121 003	8
	BSHCS 5/16-18 x 1/2	30-524	8

* Not Shown
 AR= As
 (Omit item 48 on
 Stainless cases)

Special Note on page 35
For Stainless Steel Gear Cases

UNIVERSAL II SERIES Model 018U2

UNIVERSAL II SERIES Model 030U2

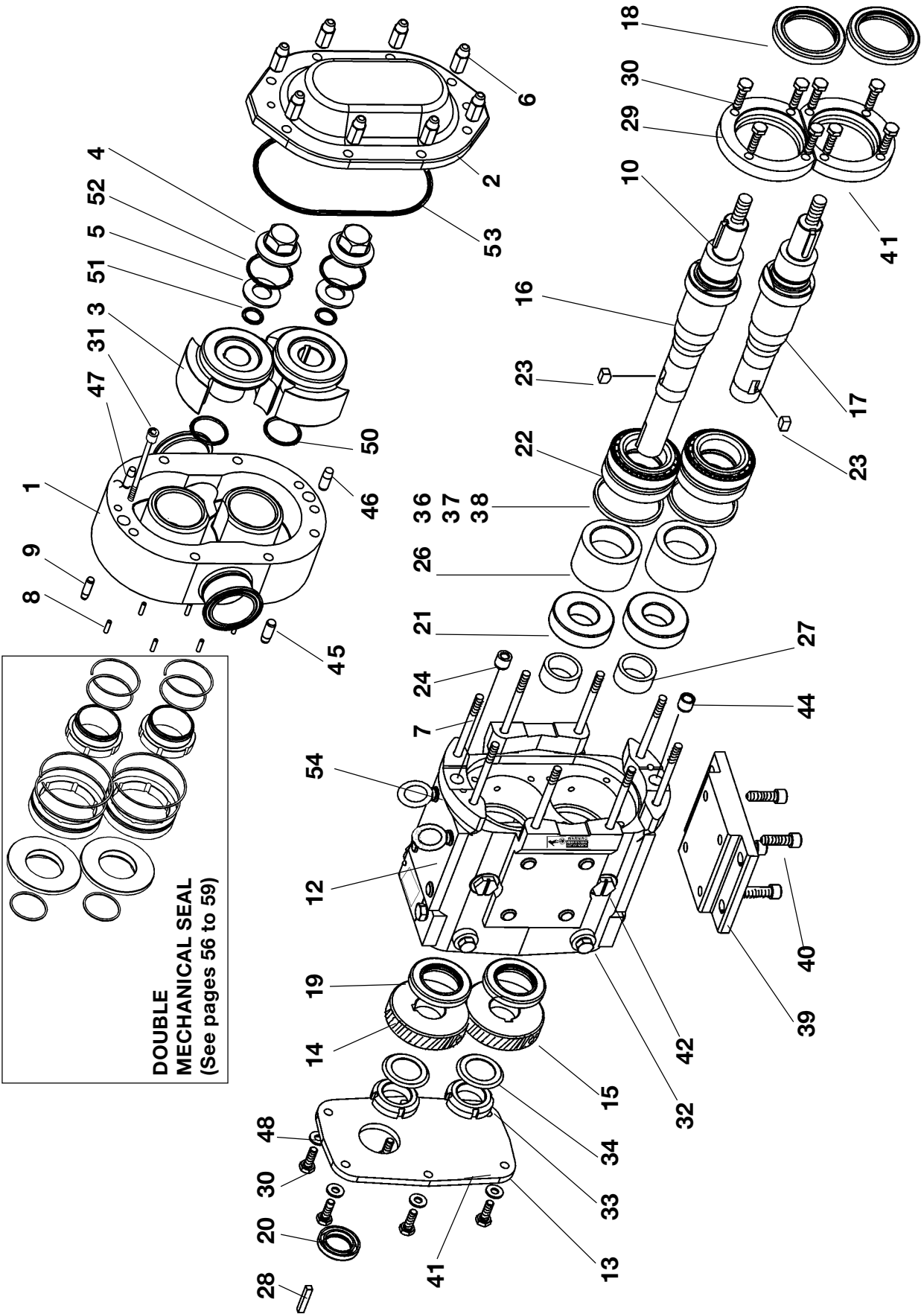

ITEM	DESCRIPTION	PART NUMBER	QTY	ITEM	DESCRIPTION	PART NUMBER	QTY
1	Body	(See Special Note)	1	36	Shim, Front Bearing 0.002"	030 054 002	4
2	Cover, Standard Stainless	101845	1	37	Shim, Front Bearing 0.010"	030 054 003	2
3	Rotor	(See Special Note)	2	38	Shim, Front Bearing 0.050"	030 054 010	4
4	Rotor Nut	101805	2	39	Mounting Foot, Gear Case	040 110 000	1
5	Washer, Belleville	101692	2		Mounting Foot, Gear Case, SS	102285	1
6	Nut, Cover	108369	8	40	Cap Screw, Soc. Hd. Zinc Plated	30-344	4
7	Stud, Body	BD0 011 4R0	8		Cap Screw, Soc. Hd. SS 18-8	30-189	4
8	Stop Pin 303 SS	101719	6	41	Silicone Sealant, RTV	000 142 300	AR
9	Dowel Pin, Upper	BD0 040 200	1	42	Cleanout Plug 1-1/16-12	41013	2
10	Key, Rotor	101821	2		Cleanout Plug 1-1/16-12 SS	102297	2
12	Gear Case	102277	1		O-Ring, Buna	N70114	2
	Gear Case, Stainless Steel	101833	1	44	Bushing, Dowel, Lower	BD0 116 100	1
13	Gear Case Cover	040 006 000	1	45	Dowel Pin, Lower	BD0 040 300	1
	Gear Case Cover, SS	102281	1	46	Dowel Pin, Cover, Lower	BD0 040 100	1
14	Gear, RH	030 007 001	1	47	Dowel Pin, Cover, Upper	BD0 040 000	1
15	Gear, LH	030 007 002	1	48	Washer, 3/8 ZP	43-194	6
16	Drive, Shaft	101754	1	49	HHCS, 5/16 -18 x .75 ZP	30-283	6
17	Short, Shaft	101755	1		HHCS, 5/16 -18 x .75 18-8	30-151	6
18	Seal, Front Grease	101717	2	*	Name Plate	001 061 002	1
	Seal, Front Grease	102289	2	*	RHDS, #2 x 1/8" 18 8 S.S.	AD0 062 000	4
19	Seal, Oil	000 030 014	2	*	Grease Fitting	BD0 092 000	4
20	Seal, Input	000 030 013	1	*	Plastic Cap, Grease Fitting	BD0 093 000	4
	Seal, Input (Stainless)	102293	1	*	Caution Label	33-62	2
21	Bearing, Rear	030 035 000	2	50	O-Ring, Rotor Hub, Buna N	N70127	2
22	Bearing, Front	101715	2		O-Ring, Rotor Hub, EPDM	E70127	
23	Key, Gear	BD0 037 000	2		O-Ring, Rotor Hub, Fluoroelastomer	V70127	
24	Dowel Bushing, Upper	BD0 116 000	1	51	O-Ring, Retainer Buna N	N70115	2
26	Spacer, Bearing	101815	2		O-Ring, Retainer EPDM	E70115	
27	Spacer, Gear	030 055 000	2		O-Ring, Retainer Fluoroelastomer	V70114	
28	Key, Motor	000 037 002	1	52	O-Ring, Rotor Nut Buna N	N70130	2
29	Bearing Retainer, Front	101811	2		O-Ring, Rotor Nut EPDM	E70130	
30	Cap Screw, Hex Hd. Zinc Plated	30-296	8		O-Ring, Rotor Nut Fluoroelastomer	V70130	
31	Cap Screw, Hex Hd. 18-8	30-29	8	53	O-Ring, Cover Buna N	N70259	1
32	Oil Plug, 1/2-20 X 1/2	30-211	2		O-Ring, Cover EPDM	E70259	
	Oil Plug, 1/2-20 X 1/2 18-8	004 046 003	6		O-Ring, Cover Fluoroelastomer	V70259	
	O-Ring, Buna N	30-526	6	54	Plug, Plastic, 3/8 "	000 121 002	8
	O-Ring, Buna N	N70112	6		BSHCS 3/8-16 x 1/2	30-528	8
33	Lock Nut	CD0 036 N00	2				
34	Lockwasher	CD0 036 W00	2				

* Not Shown

AR= As Required

(Omit Item 48 on

Stainless cases)

Special Note on page 35

For Stainless Steel Gear Cases

UNIVERSAL II SERIES Model 030U2

UNIVERSAL II SERIES Model 045U2

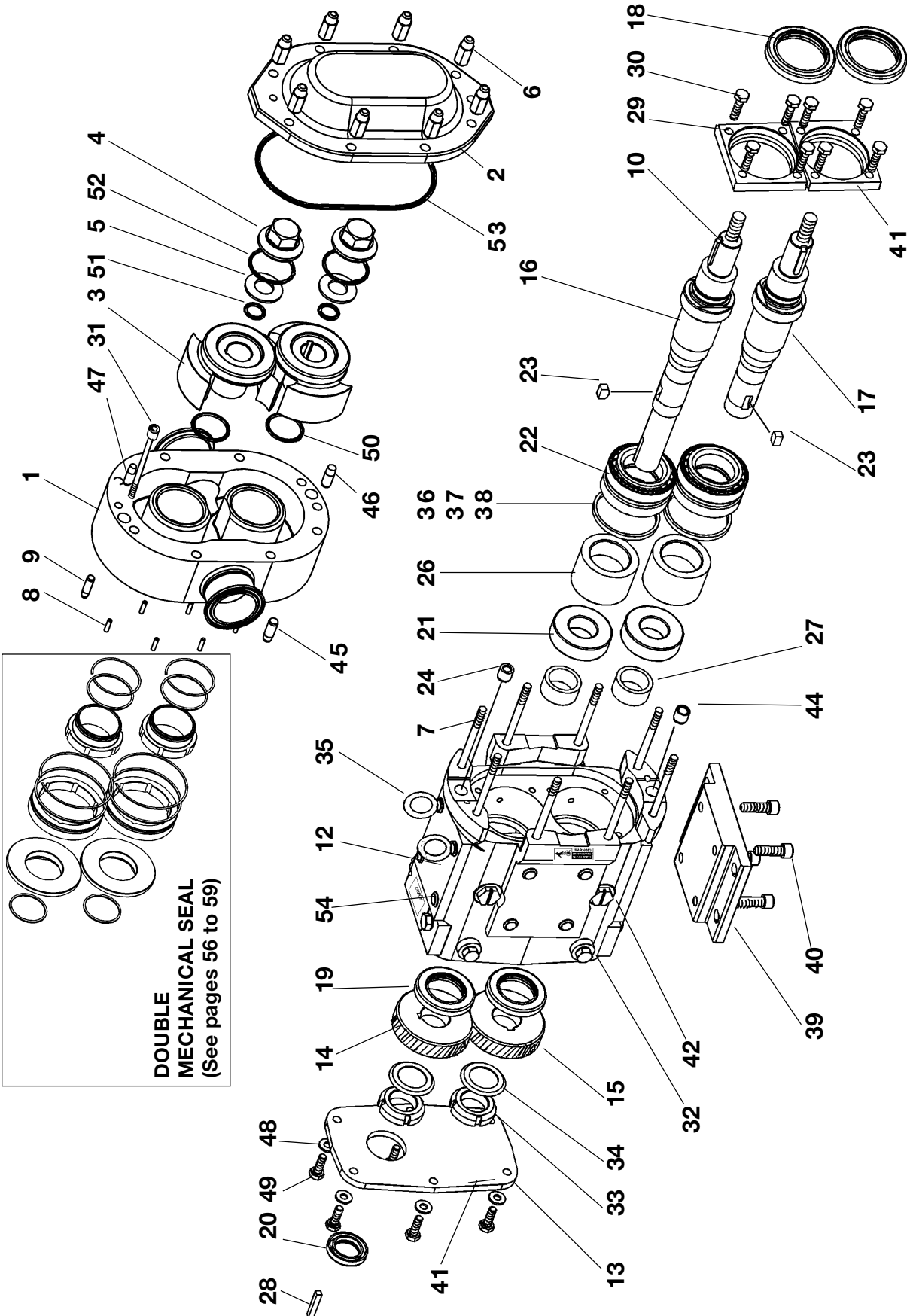

DOUBLE MECHANICAL SEAL
(See pages 56 to 59)

ITEM	DESCRIPTION	PART NUMBER	QTY
1	Body	(See Special Note)	1
2	Cover, Standard Stainless	101848	1
3	Rotor	(See Special Note)	2
4	Rotor Nut	101806	2
5	Washer, Belleville	101693	2
6	Nut, Cover	108371	8
7	Stud, Body	107242	8
8	Stop Pin 303 SS	101720	6
9	Dowel Pin, Upper	CD0 040 R00	1
10	Key, Rotor	110826	2
12	Gear Case	070 105 000	1
	Gear Case, Stainless Steel	101835	1
13	Gear Case Cover	070 006 000	1
	Gear Case Cover, SS	102282	1
14	Gear, RH	060 007 001	1
15	Gear, LH	060 007 002	1
16	Drive, Shaft	110021	1
17	Short, Shaft	110022	1
18	Seal, Front Grease, Std	102829	2
	Seal, Front Grease, Stainless	102290	2
19	Seal, Oil	000 030 011	2
20	Seal, Input	000 030 012	1
	Seal, Input (Stainless)	102294	1
21	Bearing, Rear	060 035 000	2
22	Bearing, Front	060 036 000	2
23	Key, Gear	060 037 000	2
24	Dowel Bushing, Upper	CD0 116 000	1
26	Spacer, Bearing	060 055 003	2
27	Spacer, Gear	060 055 000	2
28	Key, Motor	000 073 003	1
29	Bearing Retainer, Square	060 080 000	2
30	Bearing Retainer, Round SS	101812	2
	Cap Screw, Hex Hd. Zinc Plated	30-351	8
31	Cap Screw, Hex Hd. SS	30-60	8
	Cap Screw, Soc. Hd., Body 18-8	30-615	2
32	Oil Plug, 3/4-16 18-8	000 046 004	6
	Oil Plug, 5/16-24 x 3/8 18-8	102296	6
	O-Ring, Buna N	N70208	6
33	Lock Nut N09	STD 236 009	2
34	Lockwasher W09	STD 136 009	2
35	Eye Bolt, 1/2-13 ZP	30-360	2

ITEM	DESCRIPTION	PART NUMBER	QTY
36	Shim, Front Bearing 0.002"	40460	4
37	Shim, Front Bearing 0.010"	40459	2
38	Shim, Front Bearing 0.050"	40458	4
39	Mounting Foot, Gear Case	070 110 000	1
	Mounting Foot, Gear Case, SS	102286	1
40	Cap Screw, Soc. Hd. Zinc Plated	30-275	4
	Cap Screw, Soc. Hd. SS 18-8	30-503	4
41	Silicone Sealant, RTV	000 142 300	AR
42	Cleanout Plug 1-1/16-12 Slot	41013	2
	Cleanout Plug 1-1/16-12 SS	102297	2
	O-Ring, Buna	N70119	2
44	Bushing, Dowel, Lower	CD0 116 100	1
45	Dowel Pin, Lower	CD0 040 R10	1
46	Dowel Pin, Cover, Lower	CD0 040 100	1
47	Dowel Pin, Cover, Upper	CD0 040 000	1
48	Washer, 3/8 ZP	43-189	6
49	Cap Screw, Hx Hd., 3/8-16 x .75"	30-314	6
	Cap Screw, Hx Hd., 3/8-16 x .75"	30-50	6
*	Name Plate	001 061 002	1
*	RHDS, #2 x 1/8" 18 8 S.S.	AD0 062 000	4
*	Grease Fitting	BD0 092 000	4
*	Plastic Cap, Grease Fitting	BD0 093 000	4
*	Plug, Plastic 5/16-18 x .5	30-524	8
*	Caution Label	33-62	2
50	O-Ring, Rotor Hub, Buna N	N70224	2
	O-Ring, Rotor Hub, EPDM	E70224	2
	O-Ring, Rotor Hub, Fluoroelastomer	V70224	2
51	O-Ring, Retainer Buna N	N70119	2
	O-Ring, Retainer EPDM	E70119	2
	O-Ring, Retainer Fluoroelastomer	V70119	2
52	O-Ring, Rotor Nut Buna N	N70227	2
	O-Ring, Rotor Nut EPDM	E70227	2
	O-Ring, Rotor Nut Fluoroelastomer	V70227	2
53	O-Ring, Cover Buna N	N70373	1
	O-Ring, Cover EPDM	E70373	1
	O-Ring, Cover Fluoroelastomer	V70373	1
54	Plug, Plastic, 1/2 "	000 121 001	6
	BSHCS 1/2-13 x 1/2	30-514	6

* Not Shown
AR= As Required
(Omit item 48 on
Stainless cases)

Special Note on page 35
For Stainless Steel Gear Cases

UNIVERSAL II SERIES Model 045U2

UNIVERSAL II SERIES Model 060U2

**DOUBLE
MECHANICAL SEAL**
(See pages 56 to 59)

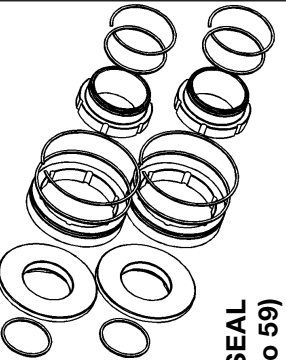
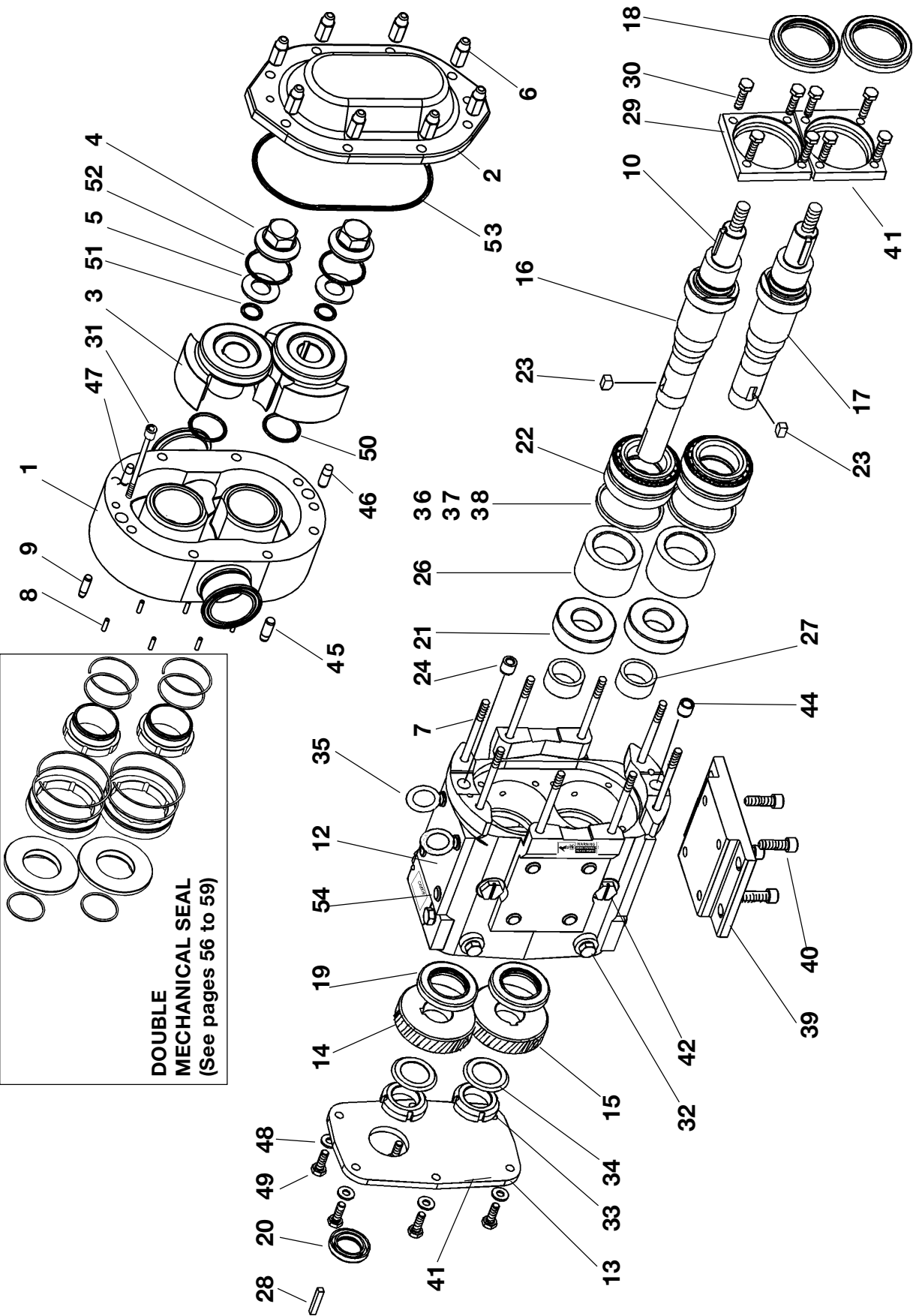



ITEM	DESCRIPTION	PART NUMBER	QTY	ITEM	DESCRIPTION	PART NUMBER	QTY
1	Body	(See Special Note)	1	36	Shim, Front Bearing 0.002"	40460	4
2	Cover, Standard Stainless	101848	1	37	Shim, Front Bearing 0.010"	40459	2
3	Rotor	(See Special Note)	2	38	Shim, Front Bearing 0.050"	40458	4
4	Rotor Nut	101806	2	39	Mounting Foot, Gear Case	070 110 000	1
5	Washer, Belleville	101693	2		Mounting Foot, Gear Case, SS	102286	1
6	Nut, Cover	108371	8	40	Cap Screw, Soc. Hd. Zinc Plated	30-275	4
7	Stud, Body	060 011 000	8		Cap Screw, Soc. Hd. SS 18-8	30-503	4
8	Stop Pin 303 SS	101720	6	41	Silicone Sealant, RTV	000 142 300	AR
9	Dowel Pin, Upper	CD0 040 R00	1	42	Cleanout Plug 1-1/16-12 Slot	41013	2
10	Key, Rotor	101823	2		Cleanout Plug 1-1/16-12 SS	102297	2
12	Gear Case	070 105 000	1		O-Ring, Buna	N70119	2
	Gear Case, Stainless Steel	101835	1	44	Bushing, Dowel, Lower	CD0 116 100	1
13	Gear Case Cover	070 006 000	1	45	Dowel Pin, Lower	CD0 040 R10	1
	Gear Case Cover, SS	102282	1	46	Dowel Pin, Cover, Lower	CD0 040 100	1
14	Gear, RH	060 007 001	1	47	Dowel Pin, Cover, Upper	CD0 040 000	1
15	Gear, LH	060 007 002	1	48	Washer, 3/8 ZP	43-189	6
16	Drive, Shaft	101766	1	49	Cap Screw, Hx Hd., 3/8-16 x .75"	30-314	6
17	Short, Shaft	101767	1		Cap Screw, Hx Hd., 3/8-16 x .75"	30-50	6
18	Seal, Front Grease, Std	102829	2	*	Name Plate	001 061 002	1
	Seal, Front Grease, Stainless	102290	2	*	RHDS, #2 x 1/8" 18 8 S.S.	AD0 062 000	4
19	Seal, Oil	000 030 011	2	*	Grease Fitting	BD0 092 000	4
20	Seal, Input	000 030 012	1	*	Plastic Cap, Grease Fitting	BD0 093 000	4
	Seal, Input (Stainless)	102294	1	*	Plug, Plastic 5/16-18 x .5	30-524	8
21	Bearing, Rear	060 035 000	2	*	Caution Label	33-62	2
22	Bearing, Front	060 036 000	2	50	O-Ring, Rotor Hub, Buna N	N70224	2
23	Key, Gear	060 037 000	2		O-Ring, Rotor Hub, EPDM	E70224	2
24	Dowel Bushing, Upper	CD0 116 000	1		O-Ring, Rotor Hub, Fluoroelastomer	V70224	2
26	Spacer, Bearing	060 055 003	2	51	O-Ring, Retainer Buna N	N70119	2
27	Spacer, Gear	060 055 000	2		O-Ring, Retainer EPDM	E70119	2
28	Key, Motor	000 073 003	1		O-Ring, Retainer Fluoroelastomer	V70119	2
29	Bearing Retainer, Square	060 080 000	2	52	O-Ring, Rotor Nut Buna N	N70227	2
	Bearing Retainer, Round SS	101812	2		O-Ring, Rotor Nut EPDM	E70227	2
30	Cap Screw, Hex Hd. Zinc Plated	30-351	8		O-Ring, Rotor Nut Fluoroelastomer	V70227	2
	Cap Screw, Hex Hd. SS	30-60	8	53	O-Ring, Cover Buna N	N70373	1
31	Cap Screw, Soc. Hd., Body 18-8	30-319	2		O-Ring, Cover EPDM	E70373	2
32	Oil Plug, 3/4-16 18-8	000 046 004	6		O-Ring, Cover Fluoroelastomer	V70373	2
	Oil Plug, 5/16-24 x 3/8 18-8	102296	6	54	Plug, Plastic, 1/2 "	000 121 001	6
	O-Ring, Buna N	N70208	6		BSHCS 1/2-13 x 1/2	30-514	6
33	Lock Nut NO9	STD 236 009	2		* Not Shown		
34	Lockwasher W09	STD 136 009	2		AR= As Required		
35	Eye Bolt, 1/2-13 ZP	30-360	2		(Omit Item 48 on Stainless cases)		

Special Note on page 35

For Stainless Steel Gear Cases

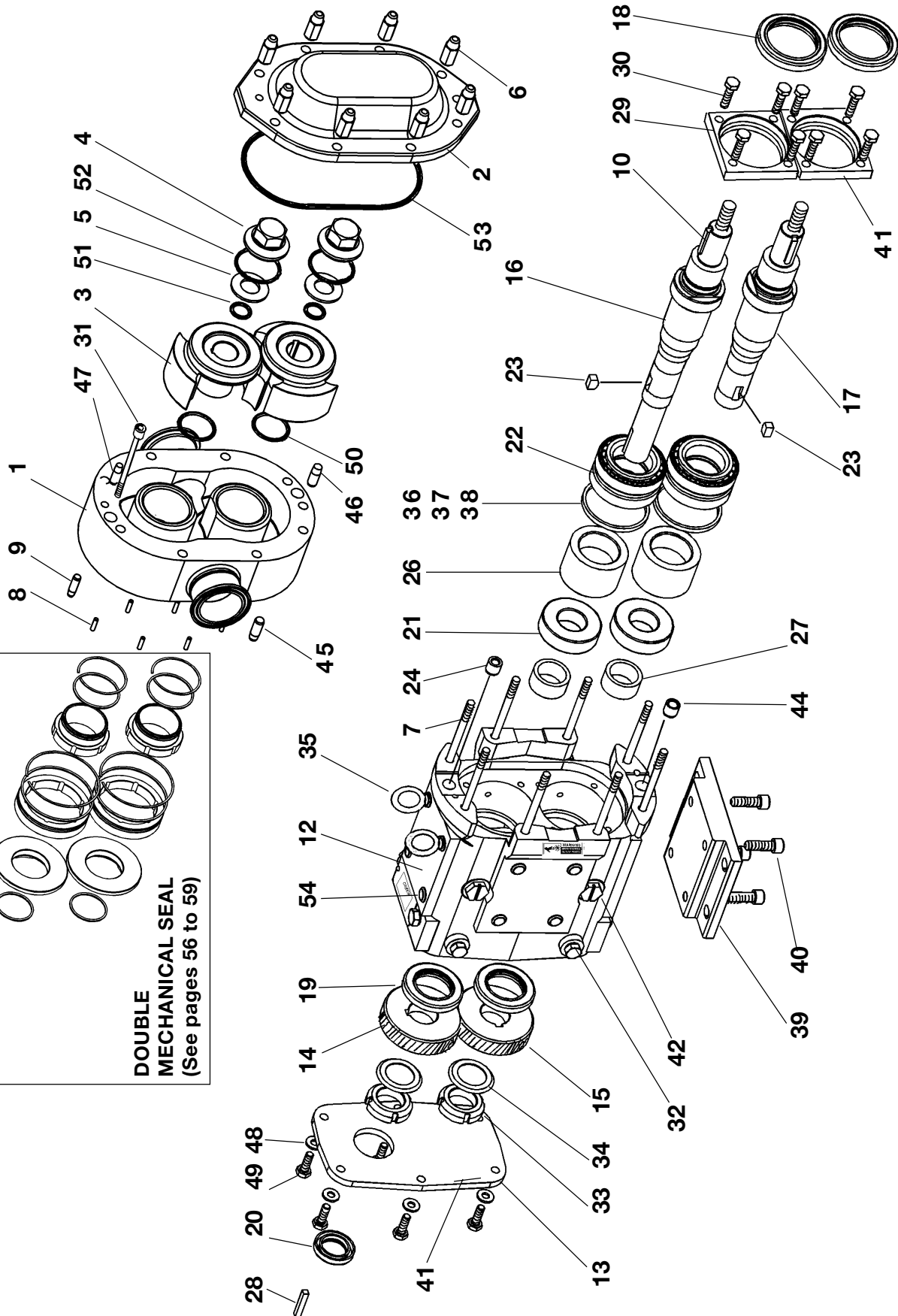
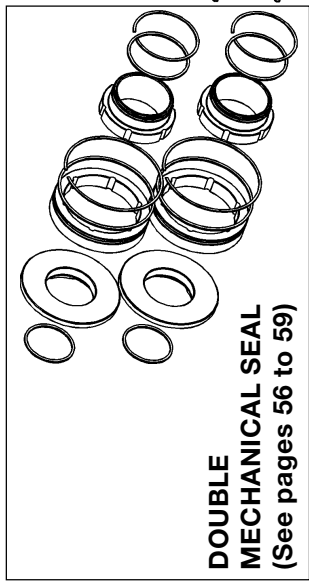
UNIVERSAL II SERIES Model 060U2



UNIVERSAL II SERIES Model 130U2

ITEM	DESCRIPTION	PART NUMBER	QTY	ITEM	DESCRIPTION	PART NUMBER	QTY
1	Body	(See Special Note)	1	36	Shim, Front Bearing 0.002"	40460	4
2	Cover, Standard Stainless	101848	1	37	Shim, Front Bearing 0.010"	40459	2
3	Rotor	(See Special Note)	2	38	Shim, Front Bearing 0.050"	40458	4
4	Rotor Nut	101806	2	39	Mounting Foot, Gear Case	070 110 000	1
5	Washer, Belleville	101693	2		Mounting Foot, Gear Case, SS	102286	1
6	Nut, Cover	108371	8	40	Cap Screw, Soc. Hd. Zinc Plated	30-275	4
7	Stud, Body	101722	8		Cap Screw, Soc. Hd. SS 18-8	30-503	4
8	Stop Pin 303 SS	101720	6	41	Silicone Sealant, RTV	000 142 300	AR
9	Dowel Pin, Upper	CD0 040 R00	1	42	Cleanout Plug 1-1/16-12 Slot	41013	2
10	Key, Rotor	101825	2		Cleanout Plug 1-1/16-12 SS	102297	2
12	Gear Case	070 105 000	1		O-Ring, Buna	N70119	2
	Gear Case, Stainless Steel	101835	1	44	Bushing, Dowel, Lower	CD0 116 100	1
13	Gear Case Cover	070 006 000	1	45	Dowel Pin, Lower	CD0 040 R10	1
	Gear Case Cover, SS	102282	1	46	Dowel Pin, Cover, Lower	CD0 040 100	1
14	Gear, RH	060 007 001	1	47	Dowel Pin, Cover, Upper	CD0 040 000	1
15	Gear, LH	060 007 002	1	48	Washer, 3/8 ZP	43-189	6
16	Drive, Shaft	101778	1	49	Cap Screw, Hx Hd., 3/8-16 x .75"	30-314	6
17	Short, Shaft	101779	1		Cap Screw, Hx Hd., 3/8-16 x .75"	30-50	6
18	Seal, Front Grease, Std	101829	2	*	Name Plate	001 061 002	1
	Seal, Front Grease (Stainless)	102290	2	*	RHDS, #2 x 1/8" 18 8 S.S.	AD0 062 000	4
19	Seal, Oil	000 030 011	2	*	Grease Fitting	BD0 092 000	4
20	Seal, Input	000 030 012	1	*	Plastic Cap, Grease Fitting	BD0 093 000	4
	Seal, Input (Stainless)	102294	1	*	Plug, Plastic 5/16-18 x .5	30-524	8
21	Bearing, Rear	060 035 000	2	*	Caution Label	33-62	2
22	Bearing, Front	060 036 000	2	50	O-Ring, Rotor Hub, Buna N	N70230	2
23	Key, Gear	060 037 000	2		O-Ring, Rotor Hub, EPDM	E70230	
24	Dowel Bushing, Upper	CD0 116 000	1		O-Ring, Rotor Hub, Fluoroelastomer	V70230	
26	Spacer, Bearing	060 055 003	2	51	O-Ring, Retainer Buna N	N70119	2
27	Spacer, Gear	060 055 000	2		O-Ring, Retainer EPDM	E70119	
28	Key, Motor	000 073 003	1		O-Ring, Retainer Fluoroelastomer	V70119	
29	Bearing Retainer, Square	0060 080 000	2	52	O-Ring, Rotor Nut Buna N	N70227	2
	Bearing Retainer, Round SS	101812	2		O-Ring, Rotor Nut EPDM	E70227	
30	Cap Screw, Hex Hd. Zinc Plated	30-351	8		O-Ring, Rotor Nut Fluoroelastomer	V70227	
	Cap Screw, Hex Hd. SS	30-60	8	53	O-Ring, Cover Buna N	N70373	1
31	Cap Screw, Soc. Hd., Body 18-8	30-423	2		O-Ring, Cover EPDM	E70373	
32	Oil Plug, 3/4-16 18-8	000 046 004	6		O-Ring, Cover Fluoroelastomer	V70373	
	Oil Plug, 5/16-24 x 3/8 18-8	102296	6	54	Plug, Plastic, 1/2"	000 121 001	6
	O-Ring, Buna N	N70208	6		BSHCS 1/2-13 x 1/2	30-514	6
33	Lock Nut N09	STD 236 009	2				
34	Lockwasher W09	STD 136 009	2				
35	Eye Bolt, 1/2-13 ZP	30-360	2				

* Not Shown

AR= As Required
(Omit Item 48 on
Stainless cases)

For Stainless Steel Gear Cases

UNIVERSAL II SERIES Model 130U2

8-28-98

UNIVERSAL II SERIES Model 180U2

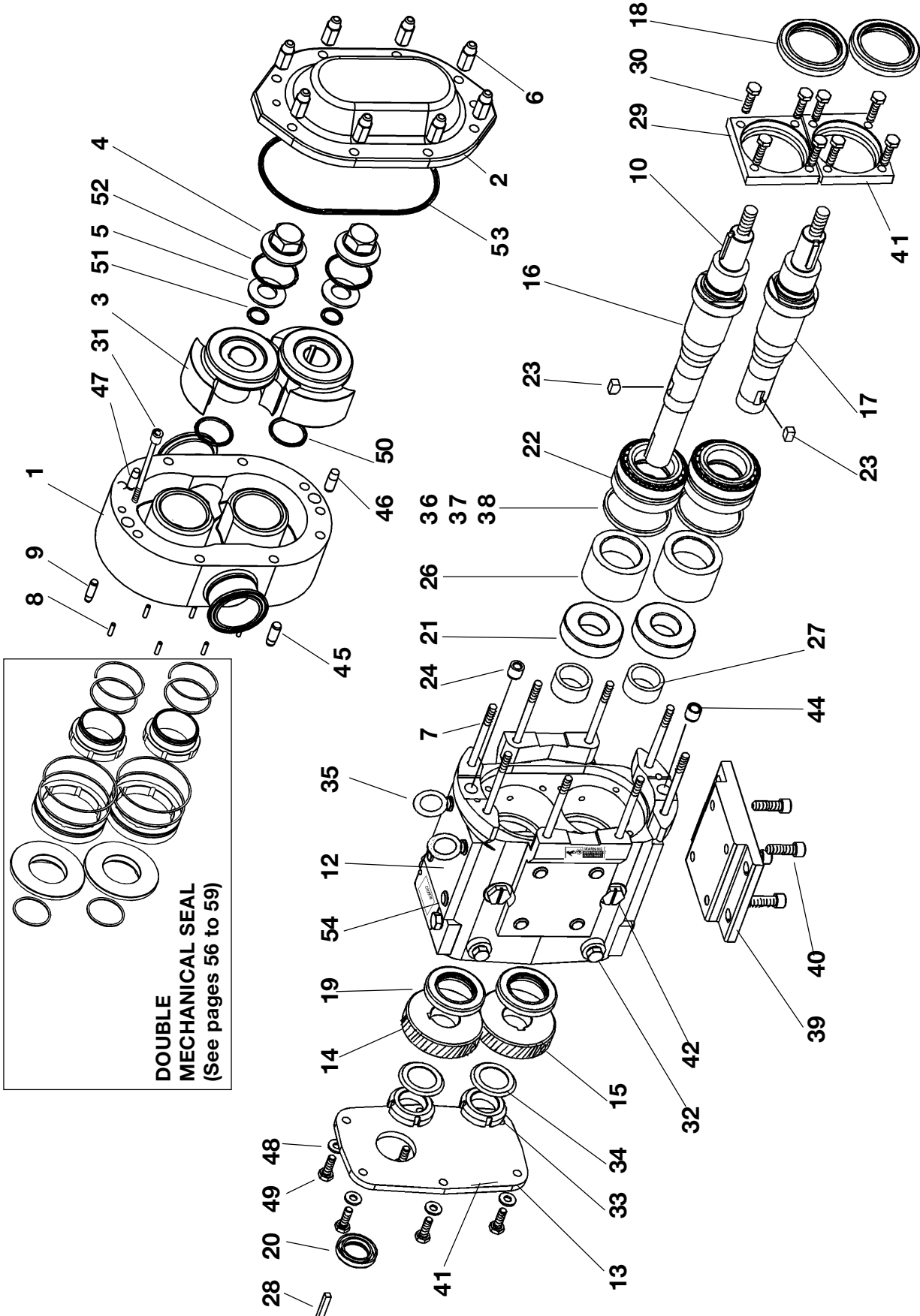

ITEM	DESCRIPTION	PART NUMBER	QTY	ITEM	DESCRIPTION	PART NUMBER	QTY
1	Body	(See Special Note)	1	39	Mounting Foot, Gear Case	230 110 000	1
2	Cover, Standard Stainless	101851	1		Mounting Foot, Gear Case SS	102287	1
3	Rotor	(See Special Note)	2	40	Cap Screw, Soc. Hd. ZP	30-111	4
4	Rotor Nut	101807	2		Cap Screw, Soc. Hd. 18-8	30-44	4
5	Washer, Belleville	101694	2	41	Silicone Sealant, RTV	000 142 300	AR
6	Nut, Cover	108372	8	42	Cleanout Plug 1-1/16-12 Slot	41013	2
7	Stud, Body	107243	8		Cleanout Plug 1-1/16-12 SS	102297	2
8	Stop Pin 303 SS	101720	6		O-Ring, Buna N	N70119	2
9	Dowel Pin, Upper	GD0 040 R00	1	44	Bushing, Dowel, Lower	CD0 116 100	1
10	Key, Rotor	110927	2	45	Dowel Pin, Lower, Gear case	CD0 040 R10	1
12	Gear Case	230 105 000	1	46	Dowel Pin, Cover, Lower	GD0 040 100	1
	Gear Case, Stainless Steel	101837	1	47	Dowel Pin, Cover, Upper	GD0 040 000	1
13	Gear Case Cover	230 006 000	1	48	Washer, ZP	43-108	8
	Gear Case Cover, SS	102283	1	49	Cap Screw, Hx Hd. 3/8-16 x .75"	30-314	8
14	Gear, RH	200 007 001	1		Cap Screw, Hx Hd. 3/8-16 x .75"	30-50	8
15	Gear, LH	200 007 002	1	*	Name Plate	001 061 002	1
16	Drive, Shaft	110023	1	*	RHDS, #2 x 1/8" 18 8 S.S.	AD0 062 000	4
17	Short, Shaft	110024	1	*	Grease Fitting	BD0 092 000	4
18	Seal, Front Grease	STD 030 002	2	*	Plastic Cap, Grease Fitting	BD0 093 000	4
	Seal, Front Grease	102291	2	*	Caution Label	33-62	2
19	Seal, Grease	STD 119 002	2	50	O-Ring, Rotor Hub, Buna N	N70230	2
20	Seal, Input	STD 030 006	1		O-Ring, Rotor Hub, EPDM	E70230	
	Seal, Input	102295	1		O-Ring, Rotor Hub, Fluoroelastomer	V70230	
21	Bearing, Rear	200 035 000	2	51	O-Ring, Retainer Buna N	N70122	2
22	Bearing, Front	200 036 000	2		O-Ring, Retainer EPDM	E70122	
23	Key, Gear	200 037 000	2		O-Ring, Retainer Fluoroelastomer	V70122	
24	Dowel Bushing, Upper	CD0 116 000	1	52	O-Ring, Rotor Nut Buna N	N70235	2
26	Spacer, Bearing	40752	2		O-Ring, Rotor Nut EPDM	E70235	
27	Spacer, Gear	200 055 000	2		O-Ring, Rotor Nut Fluoroelastomer	V70235	
28	Key, Motor	000 037 004	1	53	O-Ring, Cover Buna N	N70381	1
29	Bearing Retainer, Front, Square	220 080 000	2		O-Ring, Cover EPDM	E70381	
	Bearing Retainer, Front, Round	10813	2	54	O-Ring, Cover Fluoroelastomer	V70381	
30	Cap Screw, Hx Hd. 3/8-16 ZP	30-351	8		Plug, Plastic, 1/2"	000 121 001	6
	Cap Screw, Hx Hd. 3/8-16 18-8	30-60	8		BSHCS 1/2-13 x 1/2	30-514	6
31	Cap Screw, Soc. Hd. 18-8	30-326	2				
32	Oil Plug, w/Washer	000 046 004	6				
	Oil Plug,	102296	6				
	O-Ring, Buna N	N70208	6				
33	Lock Nut N11	STD 236 011	2				
34	Lockwasher W11	STD 136 011	2				
35	Eye Bolt, 1/2-13	30-360	2				
36	Shim, Front Bearing 0.002"	220 054 002	4				
37	Shim, Front Bearing 0.010"	220 054 010	2				
38	Shim, Front Bearing 0.050"	220 054 050	4				

* Not Shown
AR= As Required
(Omit Item 48 on
Stainless Cases)

UNIVERSAL II SERIES Model 180U2

Special Note on page 35
For Stainless Steel Gear Cases
8-28-98

UNIVERSAL II SERIES Model 220U2

DOUBLE MECHANICAL SEAL
(See pages 56 to 59)

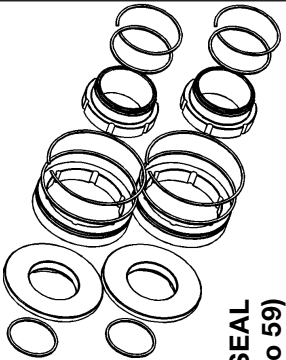
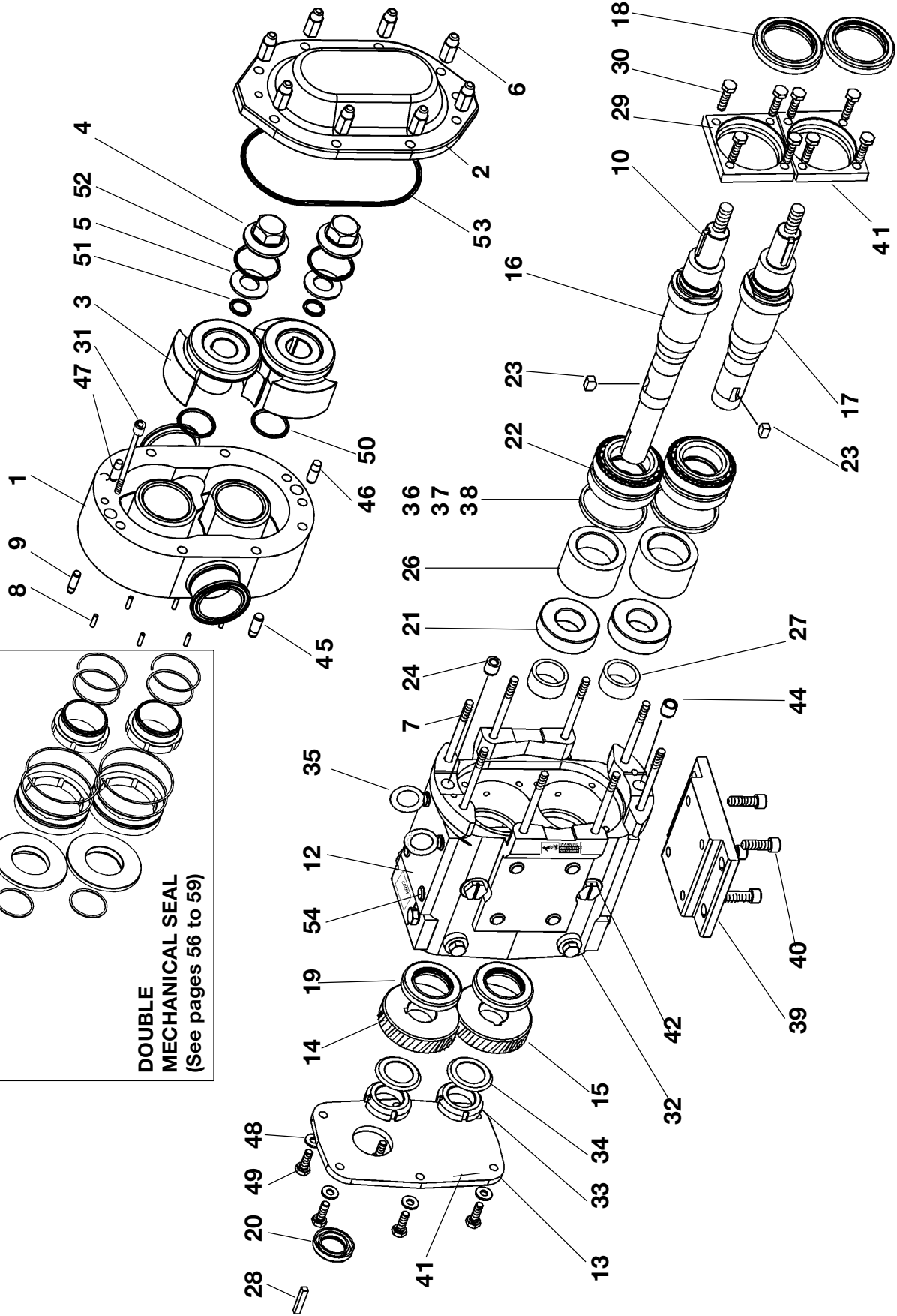
ITEM	DESCRIPTION	PART NUMBER	QTY
1	Body	(See Special Note)	1
2	Cover, Standard Stainless	101851	1
3	Rotor	(See Special Note)	2
4	Rotor Nut	101807	2
5	Washer, Belleville	101694	2
6	Nut, Cover	108372	8
7	Stud, Body	GGA 011 000	8
8	Stop Pin 303 SS	101720	6
9	Dowel Pin, Upper	GD0 040 R00	1
10	Key, Rotor	101827	2
12	Gear Case	230 105 000	1
13	Gear Case, Stainless Steel	101837	1
14	Gear Case Cover, SS	230 006 000	1
14	Gear, RH	102283	1
15	Gear, LH	200 007 001	1
16	Drive, Shaft	200 007 002	1
17	Short, Shaft	101788	1
17	Seal, Front Grease	101789	1
18	Seal, Front Grease	STD 030 002	2
19	Seal, Front Grease	102291	2
19	Seal, Grease	STD 119 002	2
20	Seal, Input	STD 030 006	1
21	Seal, Input	102295	1
21	Bearing, Rear	200 035 000	2
22	Bearing, Front	200 036 000	2
23	Key, Gear	200 037 000	2
24	Dowel Bushing, Upper	CD0 116 000	1
26	Spacer, Bearing	40752	2
27	Spacer, Gear	200 055 000	2
28	Key, Motor	000 037 004	1
29	Bearing Retainer, Front, Square	220 080 000	2
30	Bearing Retainer, Front, Round	10813	2
30	Cap Screw, Hx. Hd. 3/8-16 ZP	30-351	8
31	Cap Screw, Hx. Hd. 3/8-16 18-8	30-60	8
31	Oil Plug, w/Washer	30-499	2
32	Oil Plug, w/Washer	000 046 004	6
32	Oil Plug, w/Washer	102296	6
33	O-Ring, Buna N	N70208	6
33	Lock Nut N11	STD 236 011	2
34	Lockwasher W11	STD 136 011	2
35	Eye Bolt, 1/2-13	30-360	2
36	Shim, Front Bearing 0.002"	220 054 002	4
37	Shim, Front Bearing 0.010"	220 054 010	2
38	Shim, Front Bearing 0.050"	220 054 050	4

* Not Shown
AR= As Required
(Omit Item 48 on
Stainless Cases)

ITEM	DESCRIPTION	PART NUMBER	QTY
39	Mounting Foot, Gear Case	230 110 000	1
40	Mounting Foot, Gear Case SS	102287	1
40	Cap Screw, Soc. Hd. ZP	30-111	4
41	Cap Screw, Soc. Hd. 18-8	30-44	4
41	Silicone Sealant, RTV	000 142 300	AR
42	Cleanout Plug 1-1/16-12 Slot	41013	2
42	Cleanout Plug 1-1/16-12 SS	102297	2
44	O-Ring, Buna N	N70119	2
44	Bushing, Dowel, Lower	CD0 116 100	1
45	Dowel Pin, Lower, Gear case	CD0 040 R10	1
46	Dowel Pin, Cover, Lower	GD0 040 100	1
47	Dowel Pin, Cover, Upper	GD0 040 000	1
48	Washer, ZP	43-108	8
49	Cap Screw, Hx Hd. 3/8-16 x .75"	30-314	8
49	Cap Screw, Hx Hd. 3/8-16 x .75"	30-50	8
*	Name Plate	001 061 002	1
*	RHDS, #2 x 1/8" 18 8 S.S.	AD0 062 000	4
*	Grease Fitting	BD0 092 000	4
*	Plastic Cap, Grease Fitting	BD0 093 000	4
*	Caution Label	33-62	2
50	O-Ring, Rotor Hub, Buna N	N70230	2
50	O-Ring, Rotor Hub, EPDM	E70230	2
51	O-Ring, Rotor Hub, Fluoroelastomer	V70230	2
51	O-Ring, Retainer Buna N	N70122	2
51	O-Ring, Retainer EPDM	E70122	2
52	O-Ring, Retainer Fluoroelastomer	V70122	2
52	O-Ring, Rotor Nut Buna N	N70235	2
52	O-Ring, Rotor Nut EPDM	E70235	2
53	O-Ring, Rotor Nut Fluoroelastomer	V70235	2
53	O-Ring, Cover Buna N	N70381	1
53	O-Ring, Cover EPDM	E70381	1
54	O-Ring, Cover Fluoroelastomer	V70381	1
54	Plug, Plastic, 1/2"	000 121 001	6
54	BSHCS 1/2-13 x 1/2	30-514	6

Special Note on page 35
For Stainless Steel Gear Cases

UNIVERSAL II SERIES Model 220U2

UNIVERSAL II SERIES Model 320U2

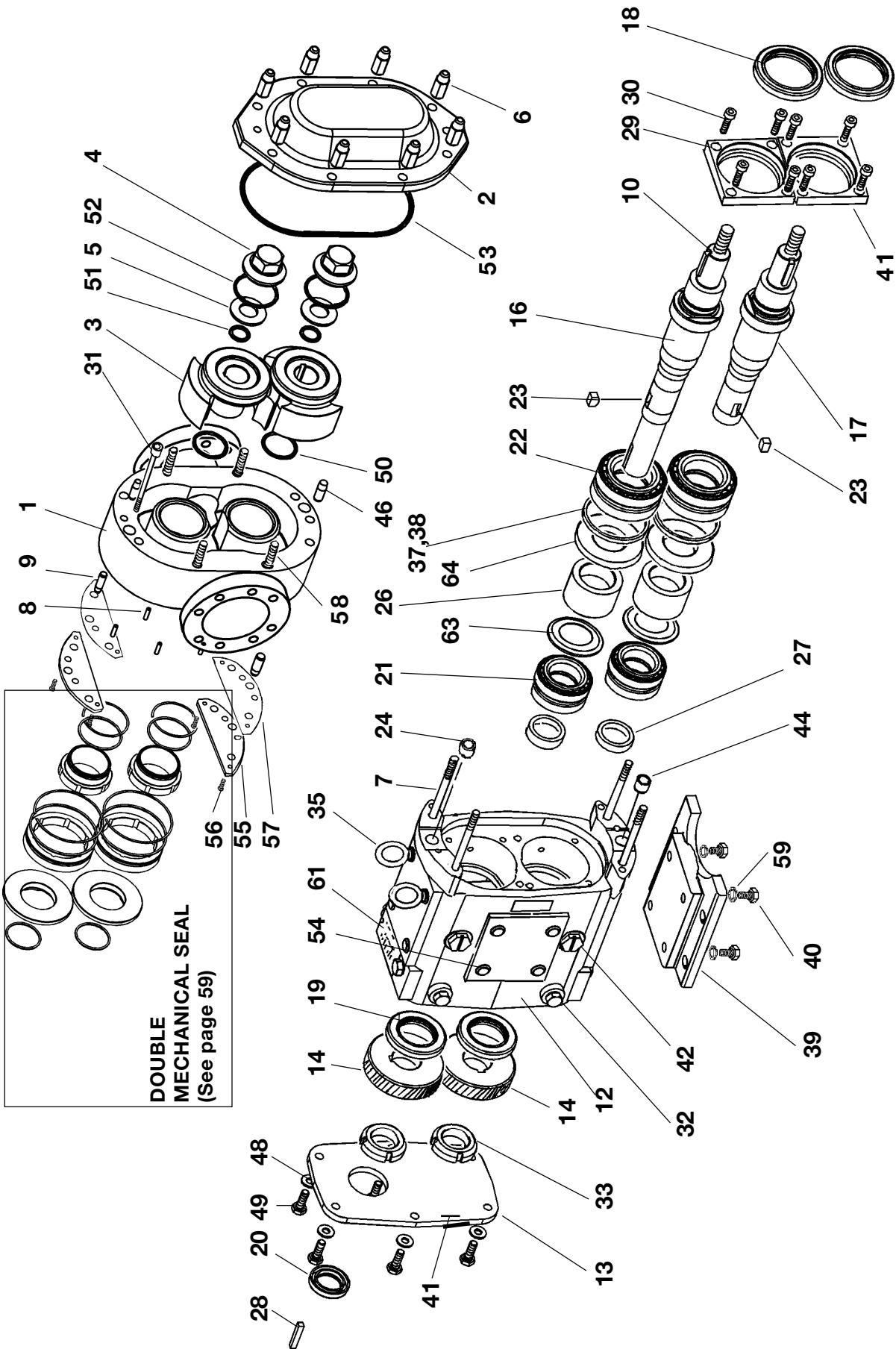

DOUBLE MECHANICAL SEAL
(See page 59)

ITEM	DESCRIPTION	PART NUMBER	QTY	ITEM	DESCRIPTION	PART NUMBER	QTY
1	Body 6.0" 150# Flange	105404	1	49	Cap Screw, Hx Hd. 3/8-16 x .75"	30-314	8
2	Cover, Standard Stainless	105406	1	*	Name Plate	001 061 015	1
3	Rotor	105427	2	*	RHDS, #2 x 1/8" 18 8 S.S.	30-355	4
4	Rotor Nut	105409	2	*	Grease Fitting	BD0 092 000	4
5	Washer, Belleville	105411	2	*	Plastic Cap, Grease Fitting	BD0 093 000	4
6	Nut, Cover	108373	8	50	O-Ring, Rotor Hub, Buna N	N70232	2
7	Stud, Body	111291	4		O-Ring, Rotor Hub, EPDM	E70232	2
8	Stop Pin 303 SS	102438	6		O-Ring, Rotor Hub, Fluoroelastomer	V70232	2
9	Dowel Pin, Rear	105871	2	51	O-Ring, Retainer Buna N	N70125	2
10	Key, Rotor	105421	2		O-Ring, Retainer EPDM	E70125	2
12	Gear Case	105478	1		O-Ring, Retainer Fluoroelastomer	V70125	2
13	Gear Case Cover	40669	1	52	O-Ring, Rotor Nut Buna N	N70237	2
14	Gear, Spur	102470	1		O-Ring, Rotor Nut EPDM	E70237	2
16	Drive, Shaft	105407	1		O-Ring, Rotor Nut Fluoroelastomer	V70237	2
17	Short, Shaft	105408	1	53	O-Ring, Cover Buna N	N70383	1
18	Seal, Front Grease	STD 030 002	2		O-Ring, Cover EPDM	E70383	1
19	Seal, Grease	102475	2		O-Ring, Cover Fluoroelastomer	V70383	1
20	Seal, Input	STD 030 004	1	54	Plug, Plastic, 1/2 "	000 121 001	6
21	Bearing, Rear	0H1 036 000	2	55	Shim Plate 320U2	105426	2
22	Bearing, Front	0H1 036 003	2	56	HS 5/16-18 x 1" Flat Head MS 18-8 SS	30-612	8
23	Key, Gear	0H1 037 000	2	57	Shim .002 320U2 Body	105866	AR
24	Dowel Bushing	0H1 116 000	2		Shim .003 320U2 Body	105867	AR
26	Spacer, Bearing	102472	2		Shim .005 320U2 Body	105968	AR
27	Spacer, Gear	102474	2		Shim .010 320U2 Body	105869	AR
28	Key, Motor	000 037 005	1		Shim .020 320U2 Body	105870	AR
29	Bearing Retainer, Front, Square	0H1 080 000	2	58	Stud 5/8-11 x 2.25 Lg	111292	4
30	Cap Screw, Soc.Hd.3/8-16 ZP	30-343	8	59	Lock Washer 1/2" ZP	43-177	4
31	Cap Screw, Soc. Hd. 18-8	30-499	2	61	Caution Plate for Pumps	33-60	2
32	Oil Plug, w/Washer	000 046 004	6	62	Caution Label	33-62	2
33	Lock Nut BH13	105697	2	64	Seal Spacer .5" long	102473	2
35	Eye Bolt, 1/2-13	30-360	2				
37	Shim, Front Bearing 0.020"	0H1 054 020	2				
38	Shim, Front Bearing 0.050"	0H1 054 050	4				
39	Mounting Foot, Gear Case	40288	1				
40	Cap Screw, Hex. Hd. ZP	30-250	4				
41	Silicone Sealant, RTV	000 142 300	AR				
42	Cleanout Plug 1-1/16-12 Slot	41013	2				
44	Bushing, Lower Dowel	0h1 116 000	2				
46	Dowel Pin, Cover	0H1 040 000	2				
48	Washer, ZP	43-189	8				

* Not Shown
AR= As Required

WAUKESHA UNIVERSAL II PUMP

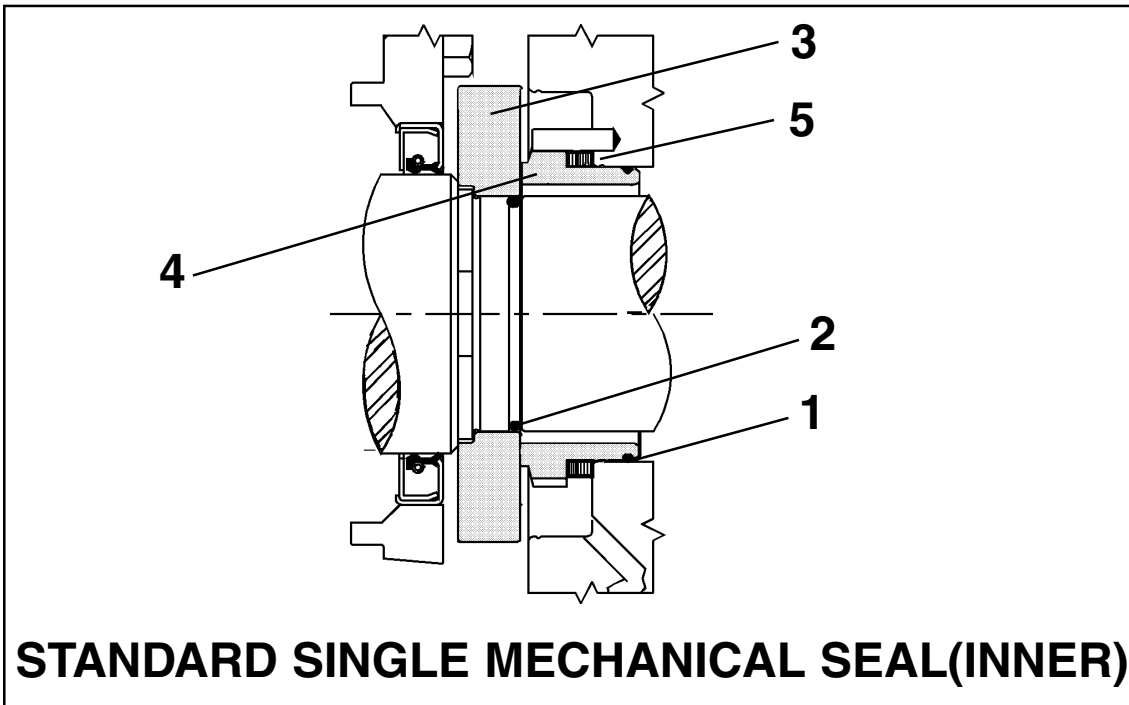

Model 006U2-015U2-018U2

Item	Description	Qty.	Part No.
1	O-Ring, Inner Buna N	2	N70028
	O-Ring, Inner EPDM	2	E70028
	O-Ring, Inner Fluoroelastomer	2	V70028
2	O-Ring, Shaft Buna N	2	N70024
	O-Ring, Shaft EPDM	2	E70024
	O-Ring, Shaft Fluoroelastomer	2	V70024
3	Seal Seat, Ceramic	2	101667
	Seal Seat, Silicon Carbide	2	101668
4	Seal Inner, Carbon	2	101651
	Seal, Inner, Ceramic	2	101652
	Seal, Inner, Tungsten Carbide	2	101654
	Seal, Inner, Silicon Carbide	2	101653
5	Wave Spring	2	101683

Model 045U2 - 060U2 - 130U2

Item	Description	Qty.	Part No.
1	O-Ring, Inner Buna N	2	N70035
	O-Ring, Inner EPDM	2	E70035
	O-Ring, Inner Fluoroelastomer	2	V70035
2	O-Ring, Shaft Buna N	2	N70133
	O-Ring, Shaft EPDM	2	E70133
	O-Ring, Shaft Fluoroelastomer	2	V70133
3	Seal Seat, Ceramic	2	101673
	Seal Seat, Silicon Carbide	2	101674
4	Seal Inner, Carbon	2	101659
	Seal, Inner, Ceramic	2	101660
	Seal, Inner, Tungsten Carbide	2	101662
	Seal, Inner, Silicon Carbide	2	101661
5	Wave Spring	2	101687

Model 030U2

Item	Description	Qty.	Part No.
1	O-Ring, Inner Buna N	2	N70031
	O-Ring, Inner EPDM	2	E70031
	O-Ring, Inner Fluoroelastomer	2	V70031
2	O-Ring, Shaft Buna N	2	N70029
	O-Ring, Shaft EPDM	2	E70029
	O-Ring, Shaft Fluoroelastomer	2	V70029
3	Seal Seat, Ceramic	2	101670
	Seal Seat, Silicon Carbide	2	101671
4	Seal Inner, Carbon	2	101655
	Seal, Inner, Ceramic	2	101656
	Seal, Inner, Tungsten Carbide	2	101658
	Seal, Inner, Silicon Carbide	2	101657
5	Wave Spring	2	101685

Model 180U2 - 220U2

Item	Description	Qty.	Part No.
1	O-Ring, Inner Buna N	2	N70041
	O-Ring, Inner EPDM	2	E70041
	O-Ring, Inner Fluoroelastomer	2	V70041
2	O-Ring, Shaft Buna N	2	N70145
	O-Ring, Shaft EPDM	2	E70145
	O-Ring, Shaft Fluoroelastomer	2	V70145
3	Seal Seat, Ceramic	2	101676
	Seal Seat, Silicon Carbide	2	101677
4	Seal Inner, Carbon	2	101663
	Seal, Inner, Ceramic	2	101664
	Seal, Inner, Tungsten Carbide	2	101666
	Seal, Inner, Silicon Carbide	2	101665
5	Wave Spring	2	101689

(Quantities are per pump)

5-4-98

WAUKESHA UNIVERSAL II PUMP

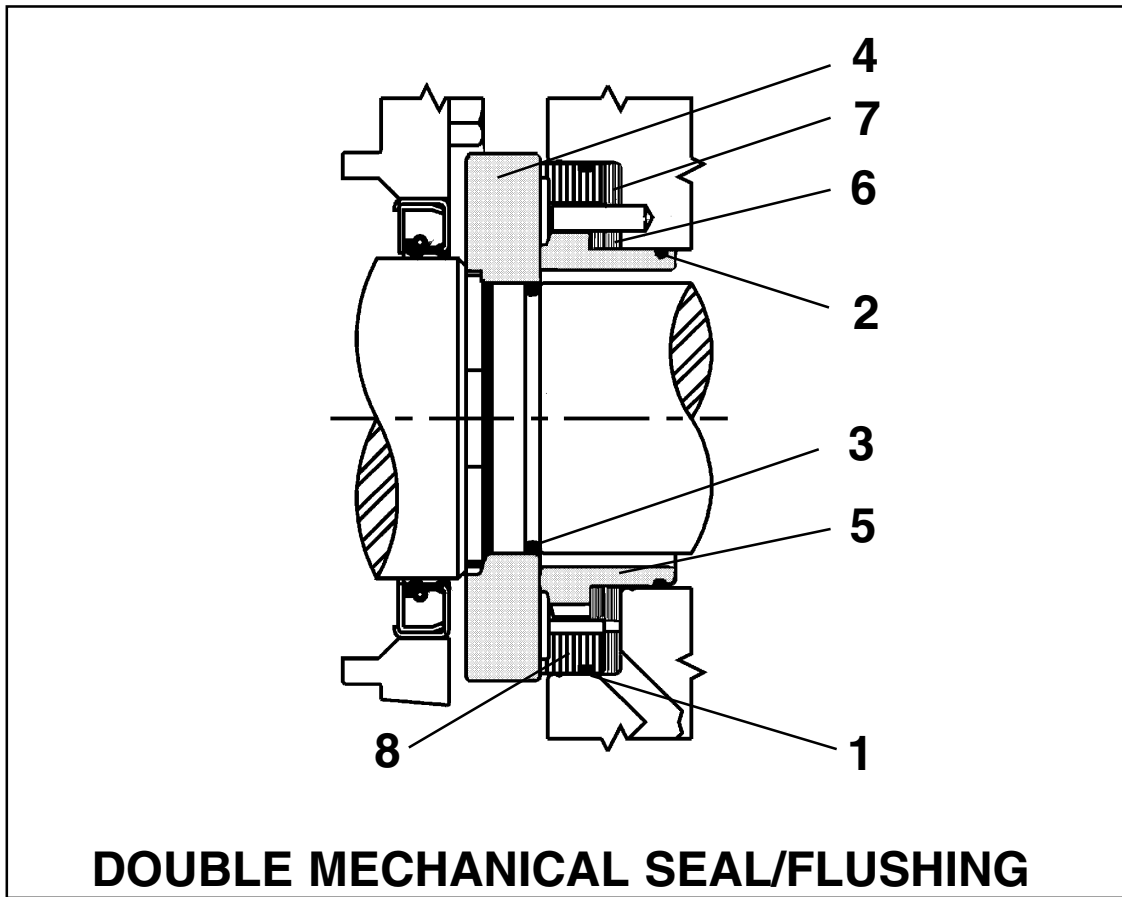

DOUBLE MECHANICAL SEAL/FLUSHING

Model 006U2-015U2-018U2

Item	Description	Qty.	Part No.
1	O-Ring, Outer Buna N	2	N70035
	O-Ring, Outer EPDM	2	E70035
	O-Ring, Outer Fluoroelastomer	2	V70035
2	O-Ring, Inner Buna N	2	N70028
	O-Ring, Inner EPDM	2	E70028
	O-Ring, Inner Fluoroelastomer	2	V70028
3	O-Ring, Shaft Buna N	2	N70024
	O-Ring, Shaft EPDM	2	E70024
	O-Ring, Shaft Fluoroelastomer	2	V70024
4	Seal Seat, Ceramic	2	101667
	Seal Seat, Silicon Carbide	2	101668
5	Seal, Inner, Carbon	2	101651
	Seal, Inner, Ceramic	2	101652
	Seal, Inner, Silicon Carbide	2	101653
	Seal, Inner, Tungsten Carbide	2	101654
	Wave Spring, Inner	2	101683
6	Wave Spring, Inner	2	101683
7	Wave Spring, Outer	2	101684
8	Outer Seal, Carbon	2	101679

Model 030U2

Item	Description	Qty.	Part No.
1	O-Ring, Outer Buna N	2	N70041
	O-Ring, Outer EPDM	2	E70041
	O-Ring, Outer Fluoroelastomer	2	V70041
2	O-Ring, Inner Buna N	2	N70031
	O-Ring, Inner EPDM	2	E70031
	O-Ring, Inner Fluoroelastomer	2	V70031
3	O-Ring, Shaft Buna N	2	N70145
	O-Ring, Shaft EPDM	2	E70145
	O-Ring, Shaft Fluoroelastomer	2	V70145
4	Seal Seat, Ceramic	2	101670
	Seal Seal Silicon Carbide	2	101671
5	Seal, Inner, Carbon	2	101655
	Seal, Inner, Ceramic	2	101656
	Seal, Inner, Silicon Carbide	2	101657
	Seal, Inner, Tungsten Carbide	2	101658
	Wave Spring, Inner	2	101685
6	Wave Spring, Inner	2	101685
7	Wave Spring, Outer	2	101686
8	Outer Seal, Carbon	2	101680

NOTE: Pump Body for Flushing Required

(Quantities are per pump)

NOTE: Pump Body for Flushing Required

CAUTION: This seal requires flushing to be connected and flowing before operating pump.

WAUKESHA UNIVERSAL II PUMP

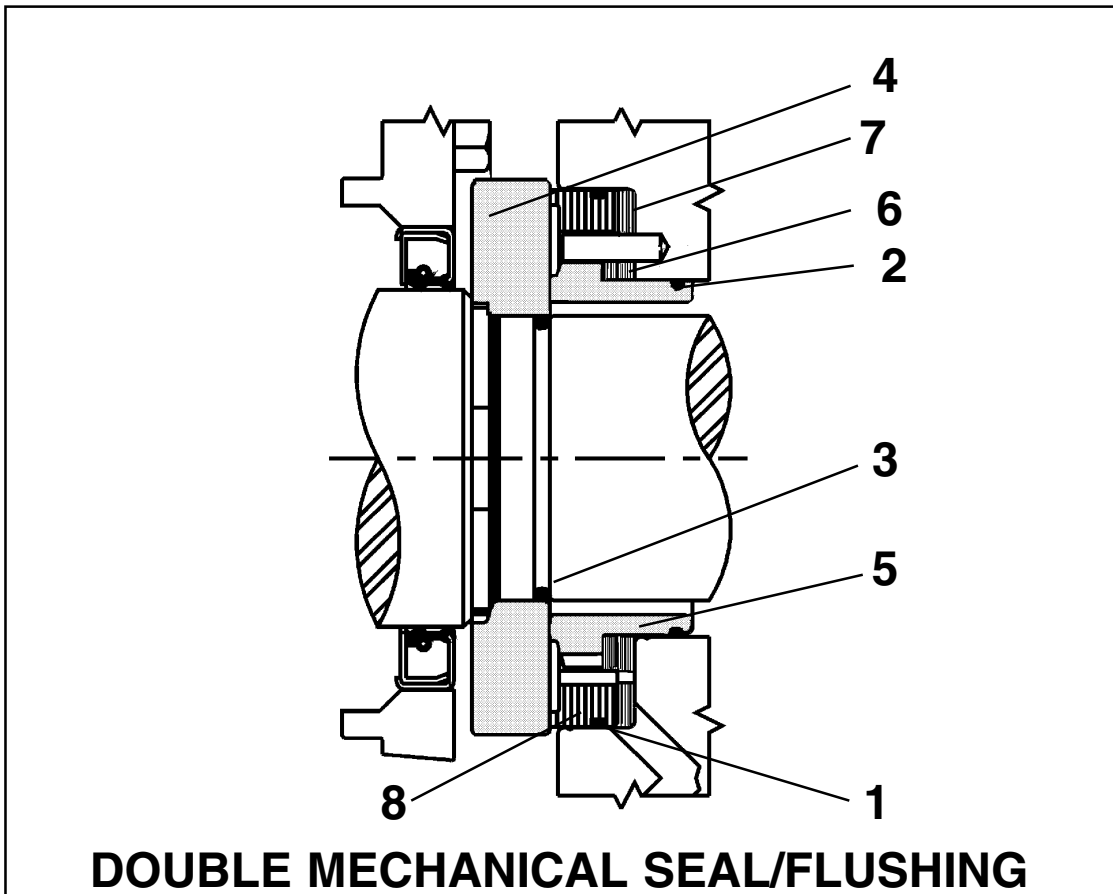

DOUBLE MECHANICAL SEAL/FLUSHING

Model 045U2 - 060U2 - 130U2

Item	Description	Qty.	Part No.
1	O-Ring, Outer Buna N	2	N70043
	O-Ring, Outer EPDM	2	E70043
	O-Ring, Outer Fluoroelastomer	2	V70043
2	O-Ring, Inner Buna N	2	N70035
	O-Ring, Inner EPDM	2	E70035
	O-Ring, Inner Fluoroelastomer	2	V70035
3	O-Ring, Shaft Buna N	2	N70133
	O-Ring, Shaft EPDM	2	E70133
	O-Ring, Shaft Fluoroelastomer	2	V70133
4	Seal Seat, Ceramic	2	101673
	Seal Seal Silicon Carbide	2	101674
5	Seal, Inner, Carbon	2	101659
	Seal, Inner, Ceramic	2	101660
	Seal, Inner, Silicon Carbide	2	101661
	Seal, Inner, Tungsten Carbide	2	101662
	Seal, Inner, Tungsten Carbide	2	101662
6	Wave Spring, Inner	2	101687
7	Wave Spring, Outer	2	101688
8	Outer Seal, Carbon	2	101681

Model 180U2 - 220U2

Item	Description	Qty.	Part No.
1	O-Ring, Outer Buna N	2	N70046
	O-Ring, Outer EPDM	2	E70046
	O-Ring, Outer Fluoroelastomer	2	V70046
2	O-Ring, Inner Buna N	2	N70041
	O-Ring, Inner EPDM	2	E70041
	O-Ring, Inner Fluoroelastomer	2	V70041
3	O-Ring, Shaft Buna N	2	N70145
	O-Ring, Shaft EPDM	2	E70145
	O-Ring, Shaft Fluoroelastomer	2	V70145
4	Seal Seat, Ceramic	2	101676
	Seal Seal Silicon Carbide	2	101677
5	Seal, Inner, Carbon	2	101663
	Seal, Inner, Ceramic	2	101664
	Seal, Inner, Silicon Carbide	2	101665
	Seal, Inner, Tungsten Carbide	2	101666
	Seal, Inner, Tungsten Carbide	2	101666
6	Wave Spring, Inner	2	101689
7	Wave Spring, Outer	2	101690
8	Outer Seal, Carbon	2	101682

NOTE: Use Flushing Pump Body

(Quantities are per pump)

CAUTION: This seal requires flushing to be connected and flowing before operating pump.

WAUKESHA UNIVERSAL II PUMP

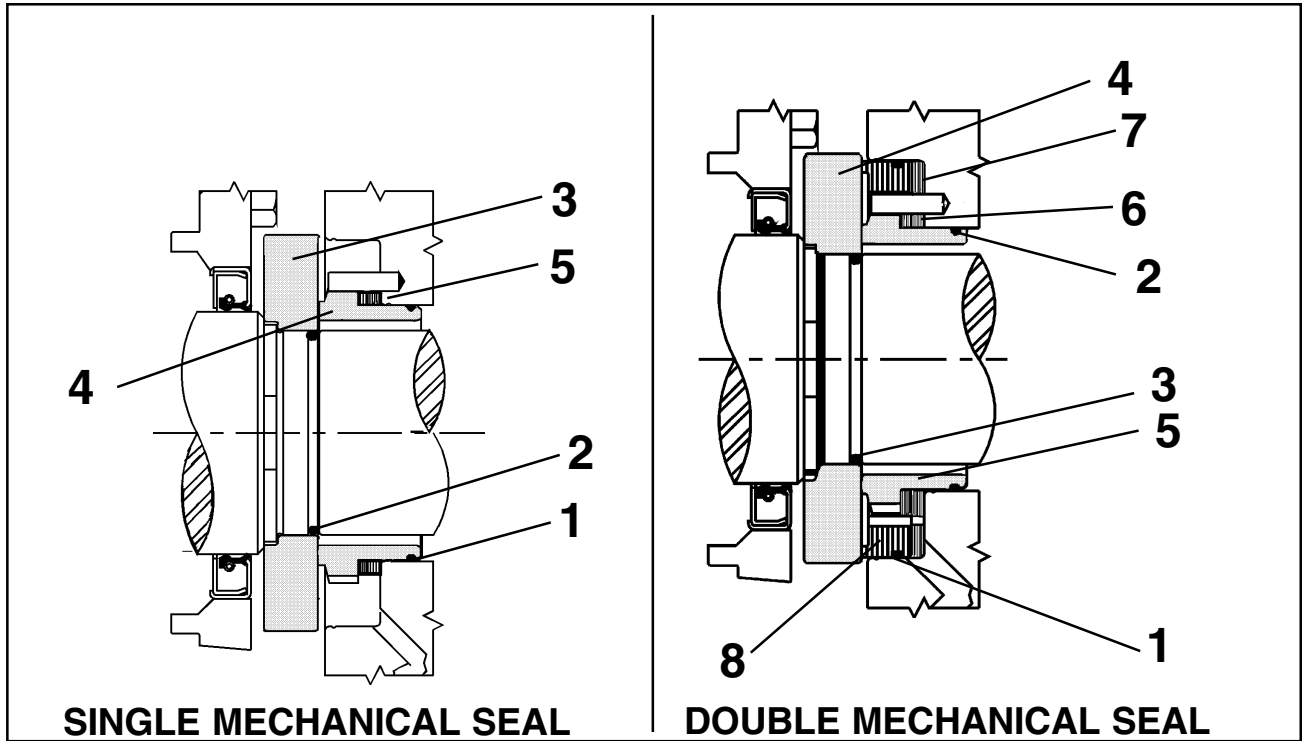

Model 320U2

Item	Description	Qty.	Part No.
1	O-Ring, Inner Buna N	2	N70154
	O-Ring, Inner EPDM	2	E70154
	O-Ring, Inner Fluoroelastomer	2	V70154
2	O-Ring, Shaft Buna N	2	N70148
	O-Ring, Shaft EPDM	2	E70148
	O-Ring, Shaft Fluoroelastomer	2	V70148
3	Seal Seat, Ceramic	2	105416
	Seal Seat, Silicon Carbide	2	105417
4	Seal Inner, Carbon	2	105412
	Seal, Inner, Ceramic	2	105413
5	Wave Spring, Inner	2	105419

Item	Description	Qty.	Part No.
1	O-Ring, Outer Buna N	2	N70160
	O-Ring, Outer EPDM	2	E70160
	O-Ring, Outer Fluoroelastomer	2	V70160
2	O-Ring, Inner Buna N	2	N70154
	O-Ring, Inner EPDM	2	E70154
	O-Ring, Inner Fluoroelastomer	2	V70154
3	O-Ring, Shaft Buna N	2	N70148
	O-Ring, Shaft EPDM	2	E70148
	O-Ring, Shaft Fluoroelastomer	2	V70148
4	Seal Seat, Ceramic	2	105416
5	Seal, Inner, Carbon	2	105412
	Seal, Inner, Ceramic	2	105413
6	Wave Spring, Inner	2	105419
7	Wave Spring, Outer	2	105420
8	Outer Seal, Carbon	2	105418

WAUKESHA UNIVERSAL II PUMP

Item	Description	QTY.
1	Seat, Seal	1
2	Seal	1
3	Seal Outer	1
6	Inner Seal O-Ring	1
7	Outer Seal O-Ring	1
8	Seal Seat O-Ring	1
9	Pin, Stop	3
10	Wave Spring Inner	1
11	Wave Spring Outer	1

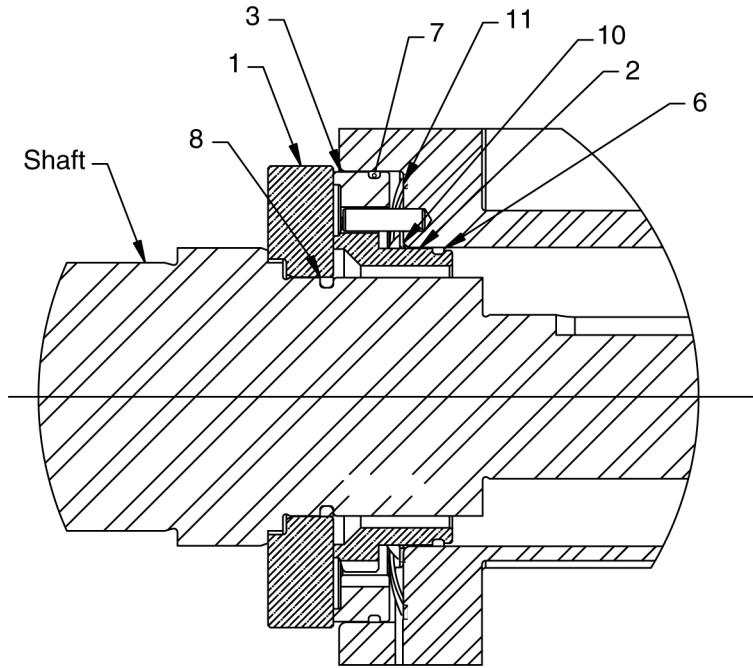

High Pressure Barrier (HPB) SEAL

Model Family	Material	Part Number			
		Inner Seal #2		Seal Seat #2	Outer Seal #3
		Standard	High Pressure Barrier Seal		
015U2	Carbon	101651	N/A	N/A	101679
	Ceramic	101652	110820	101667	N/A
	Silicon Carbide	101653	110821	101668	N/A
	Tungsten Carbide	101654	122324	119509	N/A
030U2	Carbon	101655	N/A	N/A	101680
	Ceramic	101656	110822	101670	N/A
	Silicon Carbide	101657	110823	101671	N/A
060U2	Tungsten Carbide	101658	122325	119510	N/A
	Carbon	101659	N/A	N/A	101681
	Ceramic	101660	110824	101673	N/A
220U2	Silicon Carbide	101661	110825	101674	N/A
	Tungsten Carbide	101662	122326	119511	N/A
	Carbon	101663	N/A	N/A	101682
320U2	Ceramic	101664	110826	101676	N/A
	Silicon Carbide	101665	110827	101677	N/A
	Tungsten Carbide	101666	122327	119512	N/A
	Carbon	105412	N/A	N/A	105418
	Ceramic	105413	110828	105416	N/A
	Silicon Carbide	105414	110829	105417	N/A
	Tungsten Carbide	105415	122328	119513	N/A

Standard Material Combinations:

Standard Seal Arrangement	
Inner Seal/Seal Seat Carbon/Ceramic	Outer Seal Carbon
Carbon/Silicon Carbide	Carbon
Ceramic/Ceramic	Carbon
Silicon Carbide/Silicon Carbide	Carbon
Tungsten Carbide/Silicon Carbide	Carbon
Tungsten Carbide/Tungsten Carbide	Carbon

Note: double seal arrangement adds outer seal to single seal combinations.

High Pressure Barrier Seal Arrangement	
Inner Seal/Seal Seat Ceramic/Ceramic	Outer Seal Carbon
Silicon Carbide/Silicon Carbide	Carbon
Tungsten Carbide/Tungsten Carbide	Carbon

Model Family	Material	Wave Spring	
		Inner Seal #10	Outer Seal #11
015U2	17-7PH SS	101683	101684
030U2		101685	101686
060U2/130U2		101687	101688
220U2		101689	101690
320U2		105419	105420

9-15-05

LABEL PLACEMENT

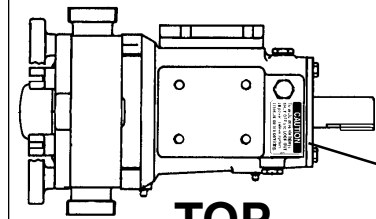

TOP

CAUTION
To avoid possible injury:
SHUT OFF and LOCK OUT
all power; relieve system
pressure before servicing.

CAUTION
To avoid possible injury;
SHUT OFF and LOCK OUT
all power; relieve system
pressure before servicing.

33-62

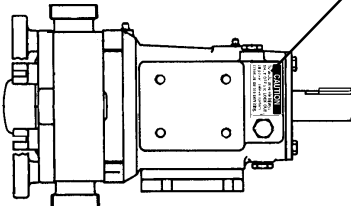

BOTTOM

1

WARNING
KEEP FINGERS
OUT OF PORTS

33-60

WARNING
KEEP FINGERS
OUT OF PORTS

33-61

WARNING
KEEP FINGERS
OUT OF PORTS

33-63

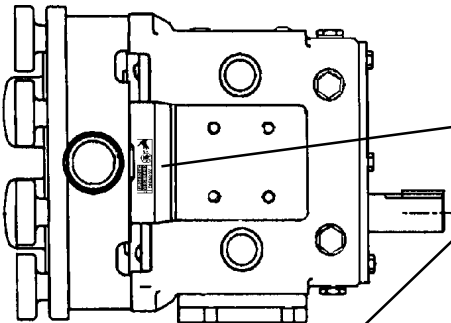

LEFT SIDE

WARNING
KEEP FINGERS
OUT OF PORTS

2

Relative Sizes

PUMP MODEL	1 33-62	2	
		33-60	33-63
006U2	●		●
015U2	●		●
018U2	●		●
030U2	●		●
045U2	●	●	
060U2	●	●	
130U2	●	●	
180U2	●	●	
220U2	●	●	
320U2	●	●	

● = 2 each

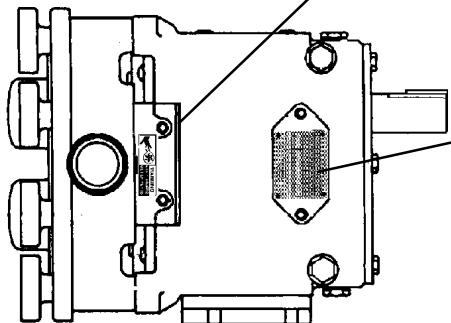

RIGHT SIDE

Waukesha
Cherry-Burrell
A DIVISION OF THE WILSON-JONES GROUP

SERIAL NO. _____
 MODEL _____
 READ AND UNDERSTAND
 OPERATION AND MAINTENANCE
 MANUAL BEFORE OPERATION.
 Delavan, WI U.S.A.

Part Number 001 061 002
Serial Number on Tag

APPLICATION INSTRUCTIONS

Apply to clean, dry surface. Remove backing; position in place, lay cover sheet over and burnish. (*Alternate method; Use soft rubber roller to press label in place.*)
Apply all labels to be readable from front of pump

Effective Date:
August 28, 1998

PARTS ORDERING

EQUIPMENT INFORMATION

Any correspondence concerning pump will require the following information be documented:

PRODUCT NAME/MODEL _____

SERIAL NUMBER: _____

DATE OF PURCHASE: _____

INVOICE NUMBER: _____

INVOICE DATE: _____

HOW TO ORDER PARTS

By Phone

Telephone your repair parts or fittings order to your Distributor. To speed your order and avoid delays, please have your **equipment model** and **serial number** and the **part numbers** from the parts list before you call your Distributor.

If you do not know your Distributors number, call Waukesha Cherry-Burrell Customer Service at:

Phone: **800-252-5200** or **414-728-1900**

Fax: **800-252-5012** or **414-728-4904**

Your call will be directed to a specialist who can provide you with Distributor information for your area.

How to Return Parts

Parts may be returned for credit, subject to the conditions of our return goods policy. To obtain authorization to return a part, contact the your Distributor.

Please give the following information:

- Invoice number and date
- Quantity
- Part Number (from parts list)
- Exact reason for return

Your Distributor will provide a Return Goods Authorization. (*Returns will not be accepted without advance authorization.*)

DISTRIBUTOR: _____

ADDRESS: _____

CITY: _____ STATE: ____ ZIP: _____

CONTACT: _____

PHONE: _____

FAX: _____

Have a problem with this Manual?

Our mission is to provide you with a quality Manual to match our quality products.

If you feel the instructions for the installation and maintenance of this product are lacking or incorrect in any manner, please tell us. Your efforts to assist us will be greatly appreciated. Thank you for your input.

Fax, E-mail or write to:

Waukesha Cherry-Burrell
Technical Writer
611 Sugar Creek Road
Delavan, Wisconsin 53115

FAX: 414-728-4904 or 800-252-5012

EMAIL: wcb@processequipment.spx.com

We will do our best to correct any problems that you find in this Manual. We will send you a copy of the modified page(s).



**Waukesha
Cherry-Burrell**
A Unit of SPX Process Equipment

®

95-03069

611 SUGAR CREEK ROAD
DELAVAN, WI 53115 U.S.A.
CUSTOMER SERVICE TELEPHONE
1-800-252-5200 OR 262-728-1900
TOLL FREE TELEFAX
1-800-252-5012 OR 262-728-4904

Effective Date: September 2005