

2004 NEW YEAR'S
RESOLUTIONS

- ✓ Reduce Maintenance Costs.
- ✓ Reduce Downtime.
- ✓ Increase Process Productivity.
- ✓ Free up Plant Space.

Resolved with Tru-Fit™

- ✓ **Tru-Fit™** offers self-aligning shafts - coupling and guard not required.
- ✓ Eliminates high maintenance costs resulting from shaft misalignment.
- ✓ Offers a variety of horsepower and gear ratios, and is available for most Universal-series pumps.
- ✓ Reduces baseplate length by an average of 20-25%.
- ✓ Available with a right angle reducer for additional space savings.
- ✓ Improved cleanability over traditional pump packages.
- ✓ Offers optional stainless steel base.



*Patent Pending

 **Waukesha
Cherry-Burrell**

® An SPX Process Equipment Operation

Phone: (800) 252-5200 • Fax: (800) 252-5012

Email: info@processequipment.spx.com

Website: www.spxprocessequipment.com

Alignment Issues?

Get in line
with Tru-Fit™.



*Patent Pending

- ▶ Tru-Fit™ offers self-aligning shafts - coupling and guard not required.
- ▶ Eliminates high maintenance costs resulting from shaft misalignment.
- ▶ Offers a variety of horsepower and gear ratios, and is available for most Universal-series pumps.
- ▶ Reduces baseplate length by an average of 20-25%.
- ▶ Available with a right angle reducer for additional space savings.
- ▶ Improved cleanability over traditional pump packages.
- ▶ Offers optional stainless steel base.



® An SPX Process Equipment Operation

Phone: (800) 252-5200 • Fax: (800) 252-5012

Email: info@processequipment.spx.com

Website: www.spxprocessequipment.com

CLOSE COUPLED PUMP DRIVE



COMPARE THE DIFFERENCE!

CLOSE COUPLED DESIGN

- No shaft alignment necessary
- No coupling guard required
- Available for models 006 through 320 UI, UII, UL
- Special base design enhances cleanability
- Reduces overall length of complete unit by an average of 20-
- Average of 80-100 gear ratios available per horsepower
- NEMA or IEC frames available, right angle reducer also available for additional space savings
- 1/2 through 60 horsepower drive options available
- Horizontal or vertical porting available
- Separate oil sump for gear reducer and timing gears
- Optional stainless steel leg kits available
- Easy to maintain

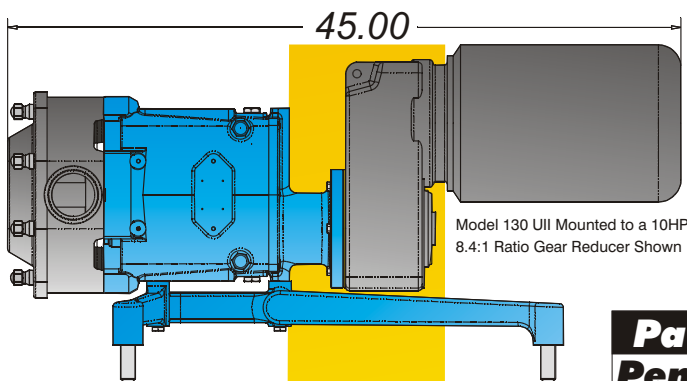
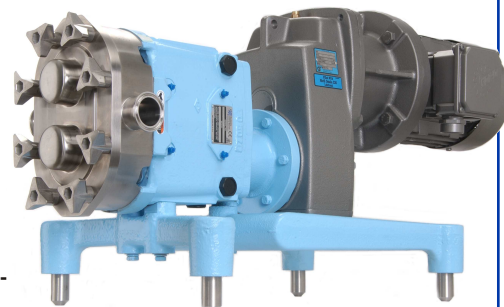

**Patent
Pending**

CONVENTIONAL DRIVE CONFIGURATION

